

40 Gb/s 4:1 Multiplexer Module



Features

- Half rate clock
- High Input Sensitivity
- Wide Operating Range, 2-44 Gb/s
- Low Output Jitter
- Low Power Consumption
- Fast Output Rise/Fall Times

Description

The MS4S1V1M is a broadband 4 to 1 MUX with continuous coverage from 2 to 44 Gb/s. The four quarter-rate data inputs are single-ended and AC-coupled, while the full-rate data output is fully differential and DC-coupled. The MUX accepts a half-rate input clock and returns a quarter-rate output clock for driving other circuits. A clock crossing adjustment pin allows correction for duty cycle distortion. Power supply bias of negative 3.6V is required.

Applications

The MS4S1V1M can be used with existing equipment to generate higher rate bit streams for use in telecom applications up to 44 Gb/s. Broadband test systems will benefit from the low power dissipation, precision connectors, and excellent output waveform characteristics. The compact size of the module allows the MS4S1V1M to be placed at the measurement plane, reducing or eliminating artifacts related to long cables.

Operating Conditions

Parameter	Minimum	Typical	Maximum	Units
Vee	-3.7	-3.6	-3.5	V

Key Specifications @ 25°C

Vee = -3.6V, Iee = 560mA, Zo = 50 Ω

Parameter	Minimum	Typical	Maximum	Units
Data Input				
Bit Rate	0.5	-	11	Gb/s
Amplitude	100	-	1000	mVpp
Clock Input				
Frequency	1	-	22	GHz
Amplitude	200	-	1400	mVpp
Power	-10	-	+7	dBm
Data Output				
Bit Rate	2	-	44	Gb/s
Amplitude (Single-Ended)	450	500	600	mVpp
Jitter RMS	-	0.5	1	psec
Jitter Pk-Pk	-	2.5	4	psec
Rise Time (20/80)	-	8	10	psec
Fall Time (20/80)	-	8	10	psec
SNR	10	-	-	dB
Clock Output				
Frequency	0.5	-	10	GHz
Amplitude	300	-	450	mVpp

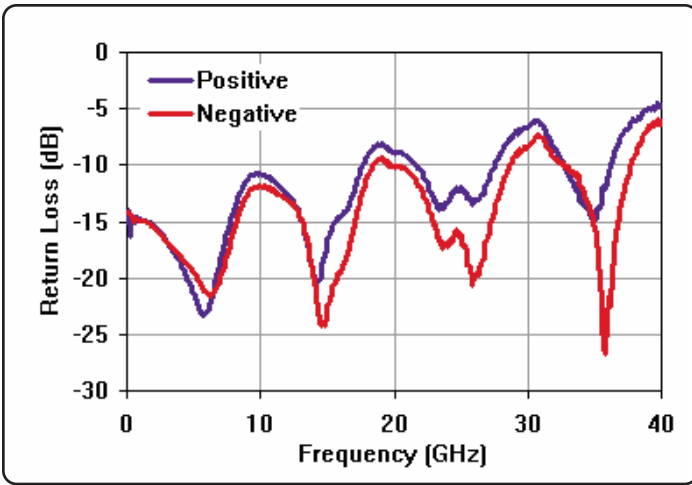

Figure 1: Data Output Return Loss

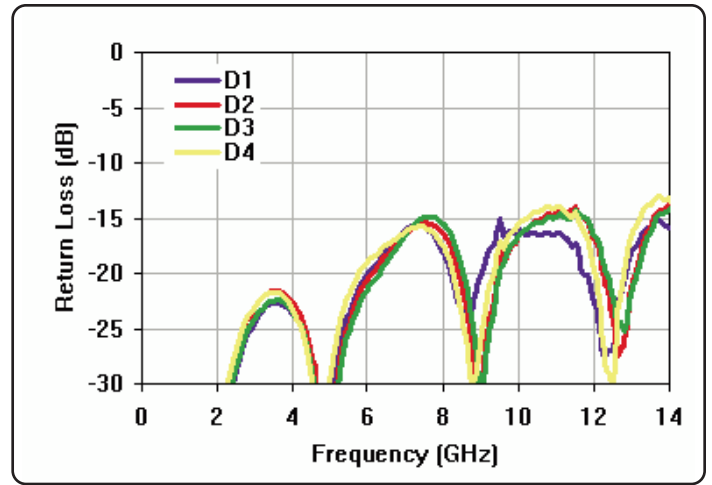

Figure 2: Data Input Return loss

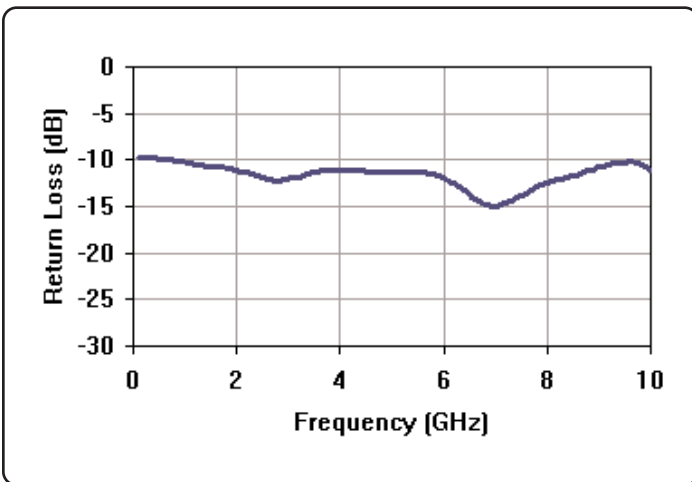

Figure 3: Clock Output Return Loss

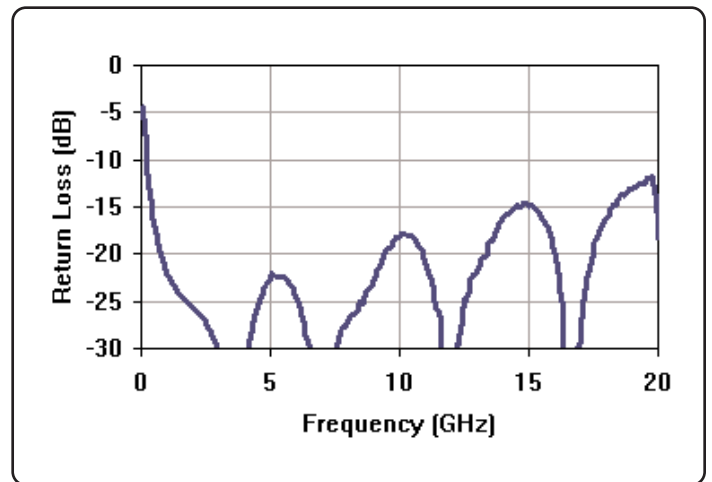

Figure 4: Clock Input Return Loss

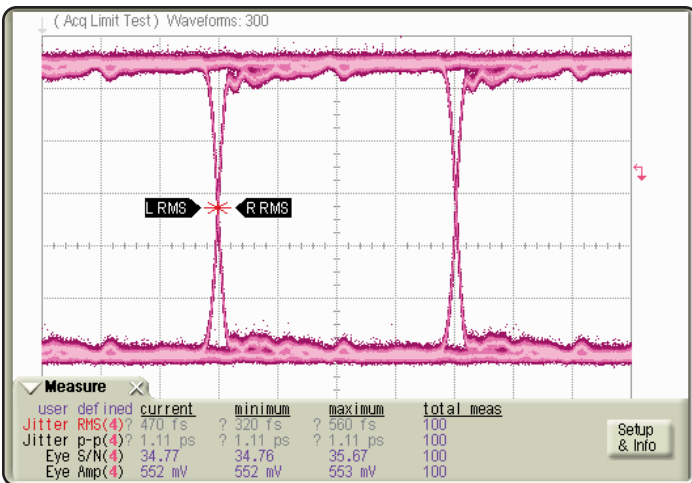

Figure 5: Data Output Waveform @ 5Gb/s
Four 1.25Gb/s, 2e31-1 Data Inputs

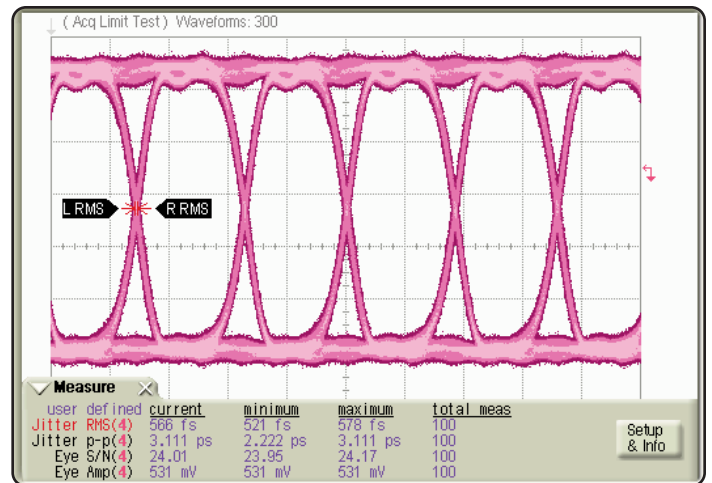

Figure 6: Data Output Waveform @ 28Gb/s
Four 7Gb/s, 2e31-1 Data Inputs

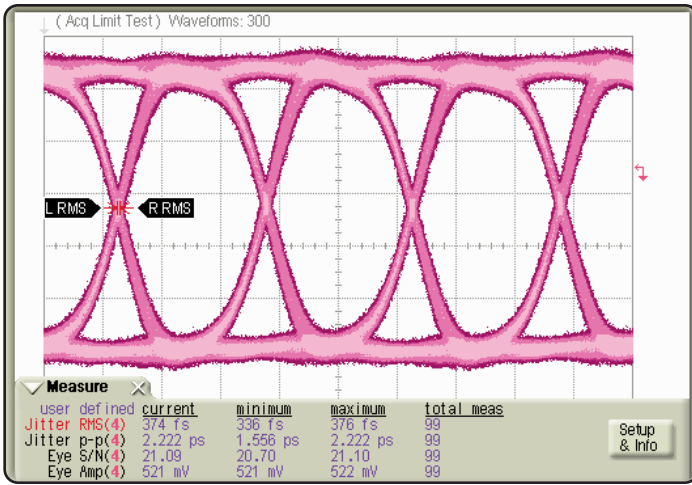

Figure 7: Data Output Waveform @ 40Gb/s
Four 10Gb/s, 2e31-1 Data Inputs

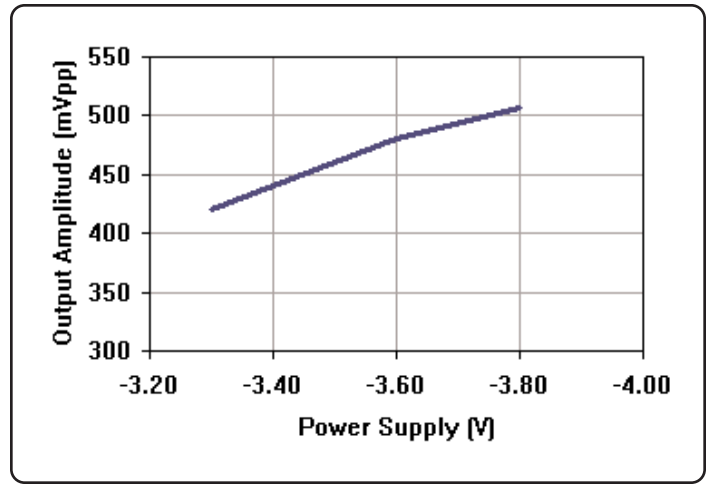

Figure 8: Data Output Amplitude vs Power Supply
Data Rate @ 40Gb/s

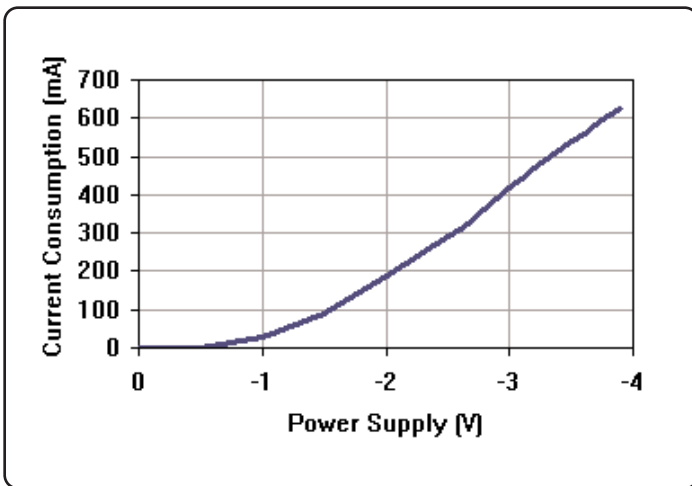

Figure 9: Power Supply Current vs Voltage

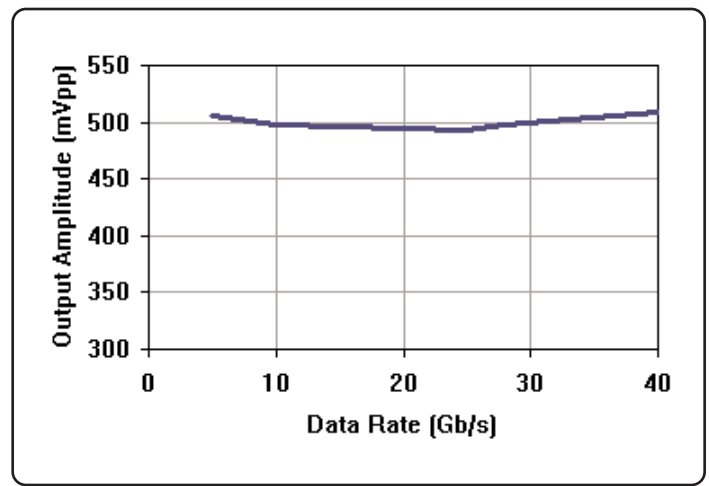

Figure 10: Data Output Amplitude vs Data Rate
Power Supply @ -3.6V

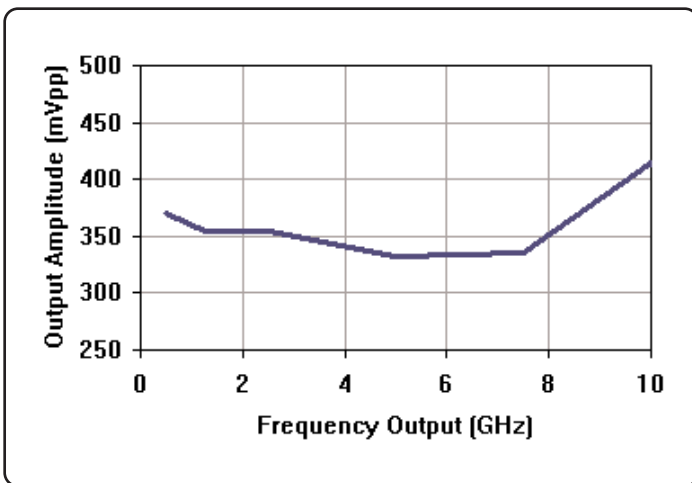

Figure 11: Clock Output Amplitude vs Frequency
Power Supply @ -3.6V

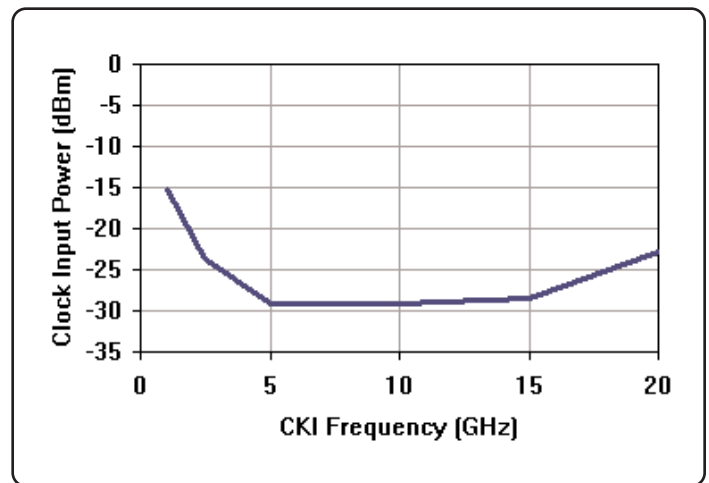
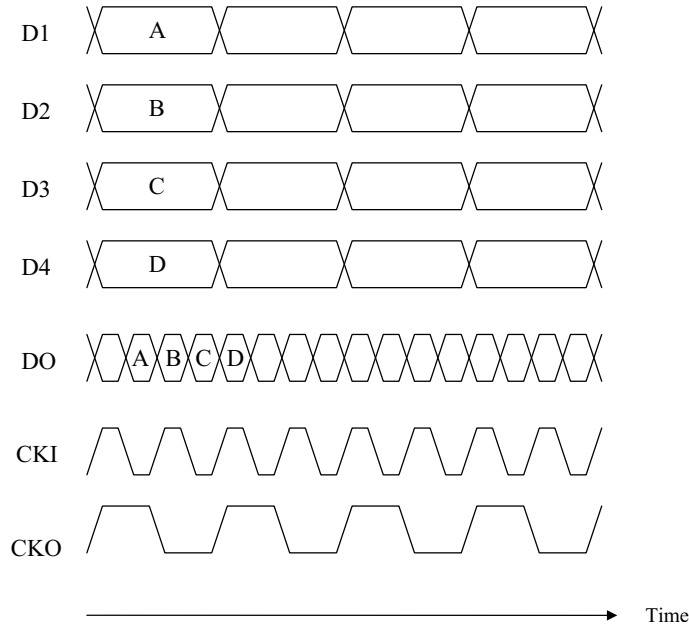

Figure 12: Clock Input Sensitivity vs Frequency
Power Supply @ -3.6V

Timing Diagram



Note: Phase relationship between signals not implied.

Functional Block Diagram

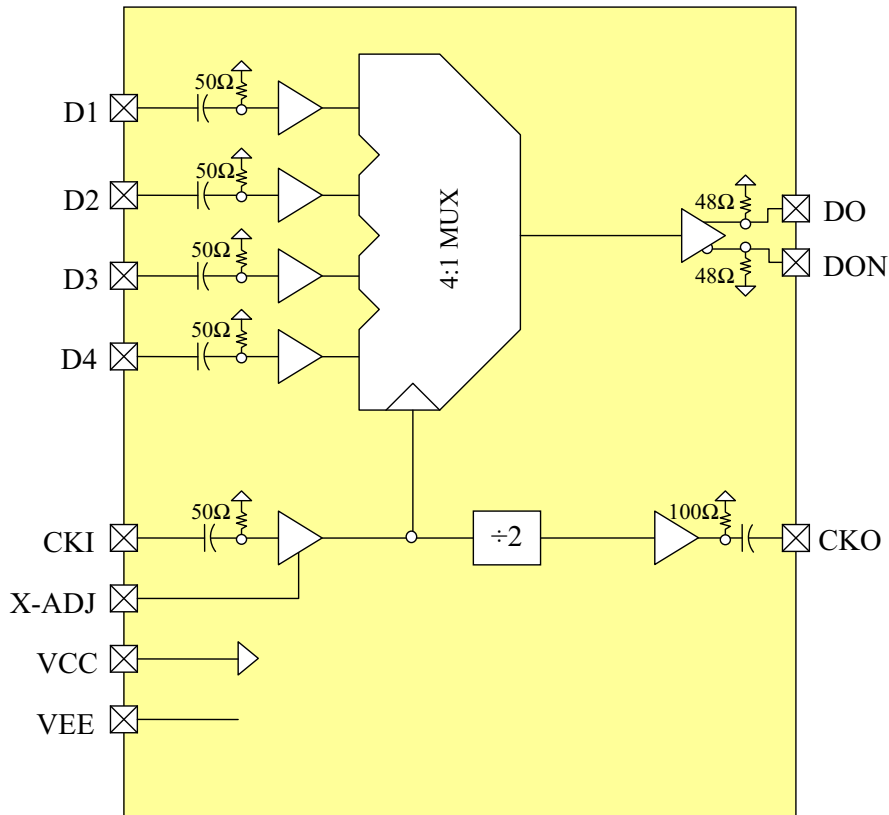

Clock Cross-Over Adjustment

The duty cycle of the input clock can have adverse effects on eye quality when deviating from 50%. Non-50% duty cycle is referred to as “duty cycle distortion” (DCD). DCD on the input clock will directly translate to double-tracking on the output eye, because adjacent bits would have unequal pulse-widths. DCD can happen by various means. For example, amplifiers operating in the non-linear regime when driven with large signals can often lead to un-evenly clipped waveforms and hence DCD. As another example, mismatches in differential circuits can cause voltage offsets between the differential signals thus leading to DCD. For these reasons, DCD can vary with frequency, temperature, and process variations.

The MS4S1V1M addresses the issue of clock DCD by providing an analog cross-over control for the input clock. This control pin allows the user to correct for a wide range of clock DCD. The cross over control is terminated internally with a 25 Ω load, and can accommodate a voltage range of +/-40mV. An external attenuator or resistor in series is recommended to prevent from overdriving and damaging this sensitive input (see figure for example). Note that the cross-over range is limited to the rise/fall times of the input clock.

MS4S1V1M Clock Cross-Over Adjust Control

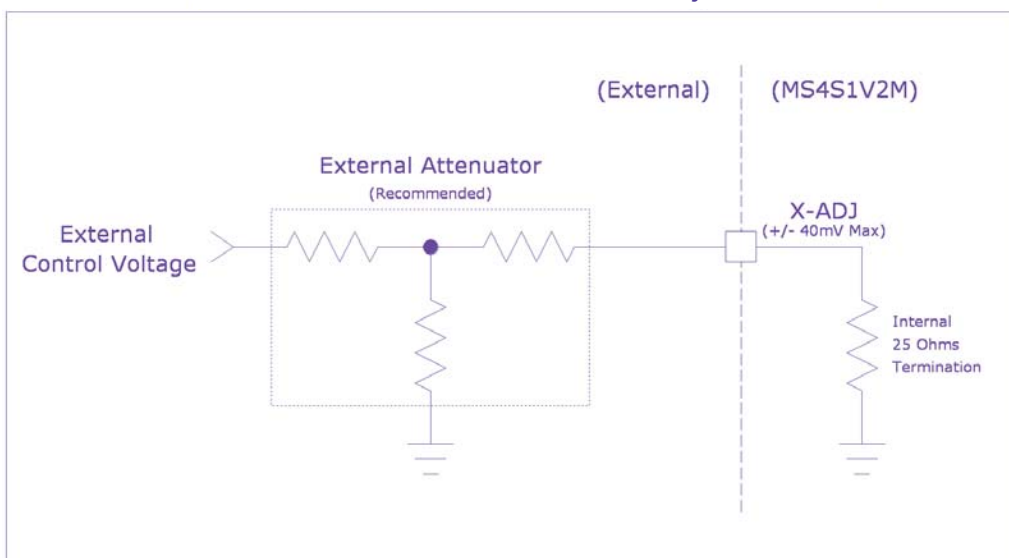

Clock Duty Cycle Waveforms

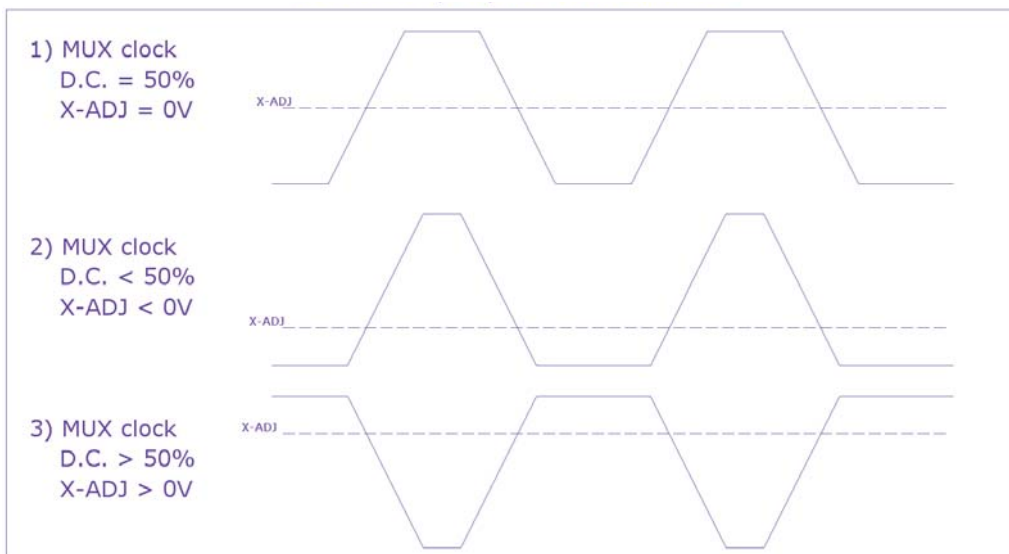

Module Outline

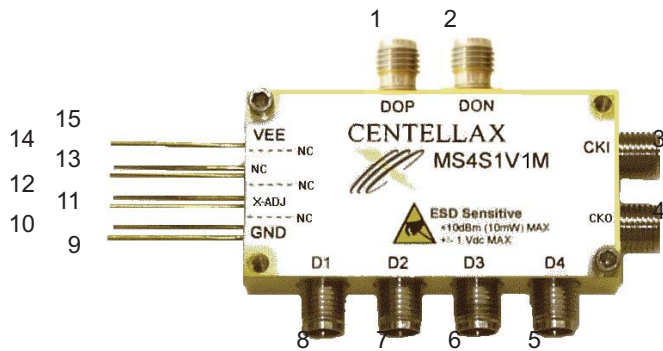

Absolute Maximum Ratings

Parameter	Value	Unit
Supply Voltage (VEE)	-4.0	V
Clock Input Power (CKI)	+10	dBm
Data Input (D1, D2, D3, D4)	2.0	V _{pp}
DC voltage (CKI, D1, D2, D3, D4)	±0.5	V
Operating Temperature	0 to 70	°C
Storage Temperature	-85 to 125	°C

Pin Description

Name	PIN	DESCRIPTION	NOTES	CONNECTOR
DOP	1	Data Channel Output	Positive Terminal of Differential Output	2.92 mm (K)
DON	2	Data Channel Output	Negative Terminal of Differential Output	2.92 mm (K)
CKI	3	Clock Input	1/2 of Bit Rate, e.g. 22GHz for 44Gb/s Single-ended input	2.92 mm (K)
CKO	4	Clock Divided Output	1/4 of Bit Rate, e.g. 11 GHz for 44Gb/s, Single-ended output	2.92 mm (K)
D4	5	Data Channel Input - Bit Position 4	Trailing/last serial data bit	2.92 mm (K)
D3	6	Data Channel Input - Bit Position 3	-	2.92 mm (K)
D2	7	Data Channel Input - Bit Position 2	-	2.92 mm (K)
D1	8	Data Channel Input - Bit Position 1	Leading/first serial data bit	2.92 mm (K)
VCC	9	RF & DC Ground	Chassis/Module Connection	-
X-ADJ	11	Clock Cross-Over Adjust	+/- 40mV max, 25Ω	-
VEE	15	Negative Supply Voltage	-3.6V @560mA, DC PIN	-
NC	10, 12-14	No Connect	-	-

Packaging Information

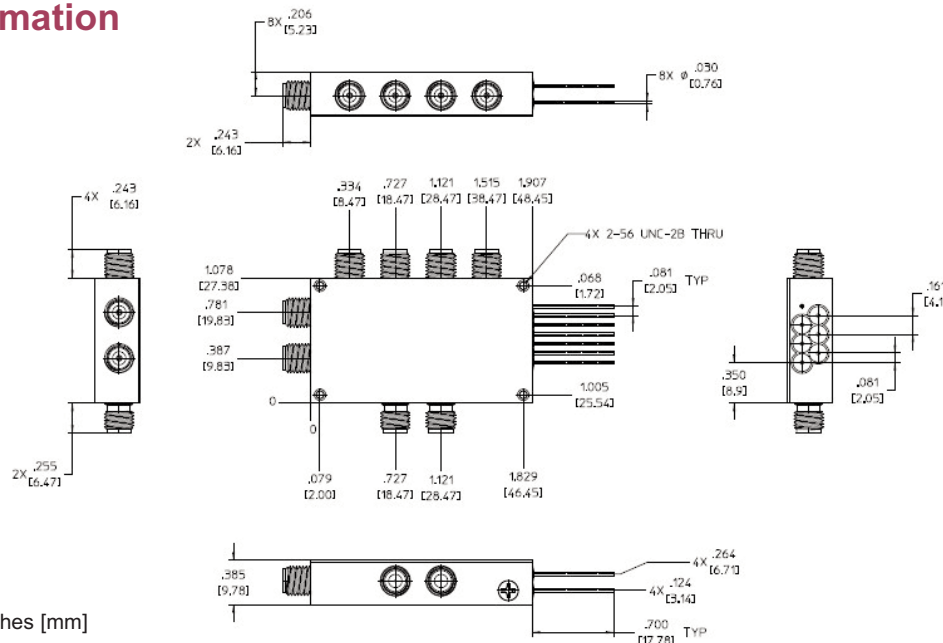

Note: all measurements in inches [mm]