

11-21 Gbps PRBS SOURCE

Operating Manual



TG1P2A

Specifications are subject to change without notice.
All Centellax trademarks and trade names are the property of Centellax Inc.

Copyright © 2003-2009 Centellax Inc.
Printed in USA. 10 Jun 2009

smd-00050 rev A

3843 Brickway Blvd, Suite 100
Santa Rosa, CA 95403
Telephone: 707.568.5900
Fax: 707.568.7647



Email:
sales@centellax.com
support@centellax.com
www.centellax.com



Table of Contents

Section 1	Introduction	2
Section 2	Description	2
Section 3	Specification	3
Section 4	Performance Verification	4
Section 5	Operation	5-9
Section 6	Application Example	9
Section 7	Warranty/Product Service	10

Section 7: *Warranty/Product Service*

Centellax, Inc. Standard Warranty Test Instrument and Accessory Products

Centellax, Inc. (“Centellax”) warrants that the Test Instrument(s) and Accessory(s) (“Product(s)”) it manufactures is/are free from defective material and workmanship for a period of one (1) year subject to the following terms and conditions. Centellax will remedy any such warranted defect subject to the followings:

This warranty requires the Product to be delivered to Centellax intact for examination with an RMA number and with all transportation charges prepaid to the factory, within one (1) year from the date of sale to the original customer. Centellax will determine in its sole discretion when such defect exists. Centellax will return the repaired or replaced Product to the customer at its cost unless the shipment needs to be expedited or the shipment is international, in which cases customer will pay for return shipment.

During the warranty period, Centellax will, at its sole option, either repair or replace Products, which prove to be defective.

This warranty is only for the benefice of the original buyer registered with Centellax and is not assignable. This warranty does not extend to any of Centellax’ Products which have been subject to misuse, neglect, accident, improper installation, or used in violation of operating instructions. This warranty does not extend to Products, which have been repaired, calibrated, or altered in any way by a facility that is not approved, in writing, by Centellax to perform such work. This warranty does not apply to any Product where the seals or serial number thereof has been removed, defaced or changed, nor to Products not of our own manufacture.

THIS WARRANTY IS IN LIEU OF ALL OTHER WARRANTIES EXPRESSED OR IMPLIED FOR THE PRODUCTS AND ALL SUCH OTHER WARRANTIES ARE HEREBY EXPRESSLY EXCLUDED. CENTELLAX SPECIFICALLY DISCLAIMS THE IMPLIED WARRANTIES OF MERCHANTABILITY AND FITNESS FOR A PARTICULAR PURPOSE.

TO THE EXTENT ALLOWED BY LAW, THE REMEDIES PROVIDED HEREIN ARE THE CUSTOMER’S SOLE AND EXCLUSIVE REMEDIES. CENTELLAX SHALL NOT BE LIABLE FOR ANY DIRECT, INDIRECT, SPECIAL, INCIDENTAL OR CONSEQUENTIAL DAMAGES, WHETHER BASED ON CONTRACT, TORT OR ANY OTHER LEGAL THEORY.

Additional information with regard to the applications and maintenance of this equipment may be available from time to time.

Centellax reserves the right to modify or change the warranty without notice.

Product Service

For information and pricing on standard factory service, please contact service@centellax.com.

Note: This product contains no user or factory adjustments. There is no calibration cycle or certificate.

3843 Brickway Blvd, Suite 100
Santa Rosa, CA 95403
Telephone: 707-568-5900
Fax: 707.568.7647



Email:
sales@centellax.com
support@centellax.com
www.centellax.com

Aux Power:

A power supply output is provided to power Centellax options such as external amplifiers for higher output swings or power level control, external dividers needed for low frequency triggers, 10/20 Gb/s error detectors, etc. The center conductor is -5V DC.

Section 6: Application Example

A typical residual or additive jitter test system is shown in the below figure. Additive jitter measurements require a precise, low jitter clock. The TG1P2A features an exceptionally low jitter internally-referenced, frequency-stable, microwave oscillator which can be used as the reference clock.

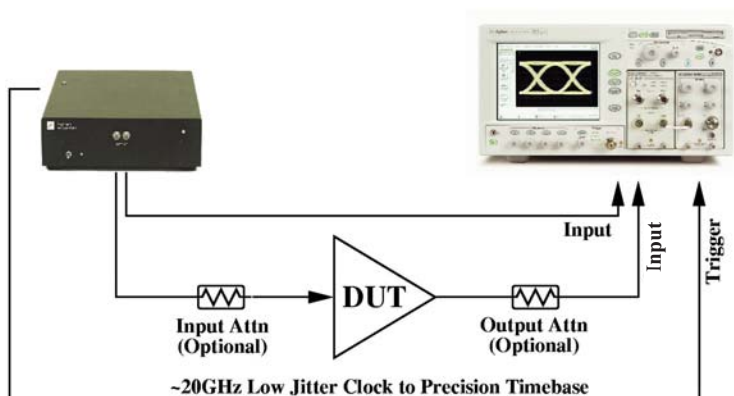

Note: to maintain the integrity of the mm-wave system the user must select the appropriate connectors and minimize the length of microwave cabling.

Centellax can provide driver amplifiers, other application specific measurement accessories and application support. Contact Centellax for test system and measurement support.

Email: support@centellax.com or call: 866-522-6888.

11-21Gbps PRBS SOURCE TG1P2A Operating Manual

Section 1: Introduction

This manual is designed to familiarize users with the fundamental operations of the Centellax TG1P2A PRBS Source.

Section 2: Description

The Centellax TG1P2A PRBS Source is a precision *Pseudo Random Bit Stream Generator* designed for 11 to 21Gb/s data systems. The source features exceptionally low jitter, fast rise time and 3 selectable bit stream pattern lengths. The Centellax TG1P2A is an easy to use, compact laboratory bench instrument.

This product has a “*Perfect Eye*” which is designed to be used as the source for testing ultra-high speed communication components and Fiber Channel systems.

Section 3: Specification

Performance Specification Table

	Description	Minimum	Typical	Maximum	Unit
DATA OUTPUT	Bit Rate TG1P2A	11	-	21	Gb/s
	RMS Jitter TG1P2A	-	400	1000	fs
	Rise/Fall Times (20-80%)	-	7	8	ps
	Amplitude	450	480	-	mVpp
	SNR	-	16	-	
	Crossing	50	55	60	%
	Output Level (High) (Low)	-50 -450	0 -	- -600	mV mV
CLOCK INPUT	Input Level	8	-	12	dBm
	Offset	-	0	-	V
	Frequency	11	-	21	GHz
PATTERN TRIGGER OUTPUT	Output Level	-	500	-	mV
	Jitter	-	20	-	ps
CLK/1 OUTPUT	Output Level	-4	-	-2	dBm
PHASE ADJUST-MENT	Phase adjustment range	-	30	-	ps
PATTERN TRIGGER	Pulse Rate: $64 * (1/\text{Output_Bit_Rate}) * (2^{n-1})$				
	Pulse Width: $64 * (1/\text{Output_Bit_Rate})$				

Trigger Outputs:

The PRBS trigger output is provided on the rear panel.

Clk/1: used with precision timebase oscilloscopes for accurate jitter characterization. Output is DC coupled, centered around 0V.

Lower frequency triggers may be provided by using an external divider from the **Clk/1** output. The TD20MCA offers excellent divider rates for triggering scopes with 2.5GHz as the highest trigger frequency available.

Pattern Trigger:

In many situations, including the use of standard timebases, the pattern trigger can provide a trigger event synchronized to the start of the PRBS pattern.

Note: $[2^{31}-1]$ pattern length trigger event occurs every ~6 seconds and will take a long time to produce a waveform. It is recommended that $[2^7-1]$ or $[2^{15}-1]$ pattern lengths be selected when using pattern trigger. Nominal trigger level should be set to -0.1V. It is recommended to use averaging for a clear view of waveform dynamics i.e. overshoot/undershoot, memory effects, rise/fall times, etc.

Pattern length switches:

Three pattern length selections are provided and selected from two toggle switches located on the rear panel. The selections are $[2^{31}-1]$, $[2^{15}-1]$ and $[2^7-1]$. The switch positions to select pattern lengths are indicated on the rear panel.

Reset:

Manual pattern reset can be effected by briefly depressing the reset switch.

Rear Panel

The TG1P2A rear panel is illustrated in the figure below. This section describes the reference clock connectors, the pattern length switches and the trigger output features.



Power:

The rear panel power switch applies power to the PRBS Source. When power is applied the PRBS is initialized and reset.

Clk Input:

External clocks are connected to this port. An external full-rate clock from 11 to 21 GHz can be used to drive the PRBS with the required drive power 10 dBm. The output bit stream ranges from 11 to 21Gb/s.

Retimer Phase Adjustment:

Use of an external clock may require a timing calibration adjustment, accessed through the top cover of the PRBS using a size C (0.07” blade) jewellers screwdriver for tuning. This tuning aligns the clock and data on the output retimer for optimal performance. This is done after a new frequency of the clock is set. View the data output eye on a scope, and optimize the phase to obtain the cleanest eye.

Caution: excessive force on the tuning mechanism will cause damage to the internal “mechanical stops”.

Section 4: Performance Verification

The figure below shows the setup required to verify performance of the source. The performance verification is a single ended output measurement. Terminate the unused output with a 1.85mm (V) 65 GHz 50Ω termination (provided). Use a 3dB 65GHz pad between the TG1P2A output and the Agilent 86118A 70 GHz electrical sampling head. The oscilloscope is triggered using the TG1P2A “Clk/1 Trigger Output” connected to the Agilent 86107A precision timebase.

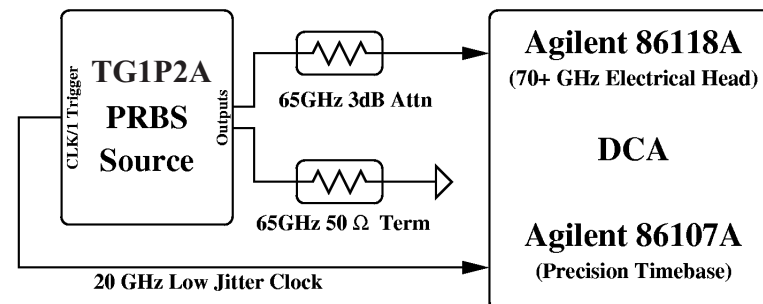

Support for verification set-up and DCA set-up procedures is available from Centellax.

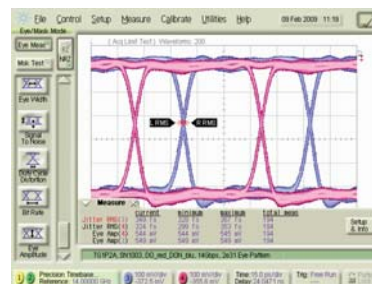

14 Gb/s Eye Output from TG1P2A

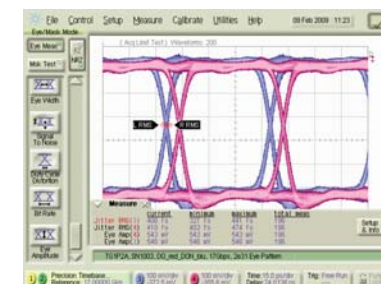

17 Gb/s Eye Output from TG1P2A

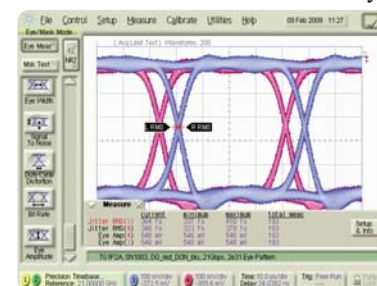

21 Gb/s Eye Output from TG1P2A

Section 5: Operation

The TG1P2A PRBS is an instrument grade source which provides state of the art waveshape - a “Perfect Eye”, required for accurate, high resolution measurements.

The TG1P2A is a versatile PRBS Source with precision triggering needed for accurate jitter and timing measurements. Completely self contained, the PRBS Source is an excellent companion to modern digital oscilloscopes such as the Agilent 86000 series Digital Communication Analyzer.

For R&D applications the TG1P2A provides the engineer with a precise, flexible PRBS Source with the triggering needed for broadband precision time-base receivers. The compact source can be placed close to the DUT and will provide simple, quick and accurate measurements. The wideband design provides very fast rise and fall time edges, low jitter and wide dynamic range. A pattern trigger output is provided for direct viewing of the data pattern on the oscilloscope.

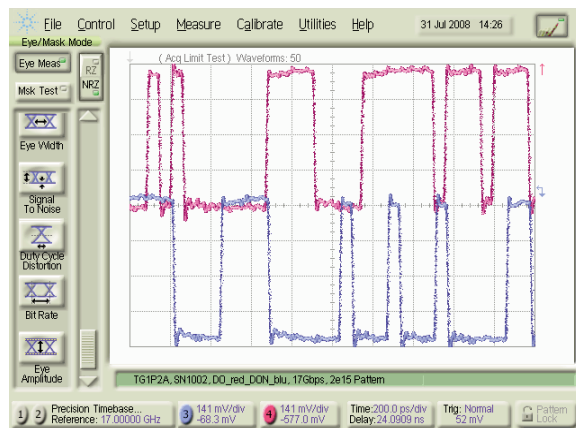

[2¹⁵-1]
Pattern
using
Pattern
Trigger

For manufacturing applications, the TG1P2A Source provides a low cost, high quality waveform needed for performance verification of Fiber Channel components.

Residual (additive) jitter and eye distortion of driver amplifiers, optical modulators, TIA, Limiting Amplifiers and 14Gb/s Fiber Channel systems can also be characterized using the TG1P2A PRBS Source.

Front Panel

The front panel LED indicator light glows when power is on.

The PRBS signal is available as a differential signal on the 1.85mm (V) female output terminals. An optional N-type of connector adaptor is available from the factory, which will have a small effect on the frequency response of the higher harmonics.

If a differential signal is not required, the unused output must be terminated with a 1.85 mm (V) 65 GHz 50Ω termination (provided by Centellax).

Outputs are CML and must be externally DC terminated with 50Ω to GND. One way to achieve DC termination while AC coupling is to use a Bias-Tee with its DC pin grounded.



Front Panel of TG1P2A

Note: When pattern lengths less than the maximum [2³¹-1] are selected and power is applied, a manual reset may be required to initiate the PRBS output.

Manual reset can also be effected by briefly depressing the Reset switch.