

# UA0L65VM Broadband Amplifier Module

## Features

- 23 dBm saturated output power
- 30 dB gain (to 50 GHz)
- 2.7 W power dissipation
- Useful gain to 65 GHz
- Small size package

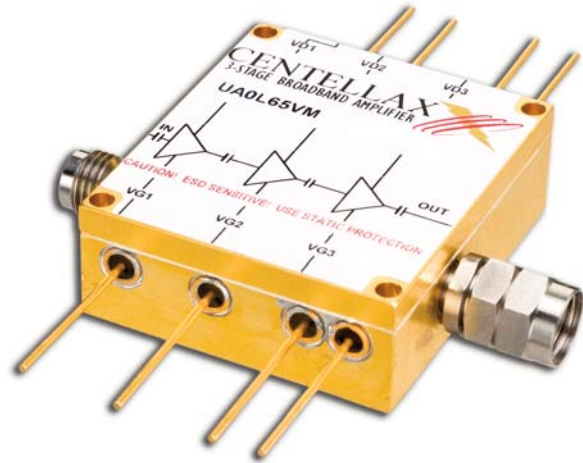

## Application

- mm-wave systems
- High frequency test instrumentation
- Broadband gain amplifier

## Description

The UA0L65VM Amplifier is a general-purpose broadband amplifier designed for microwave communications, test equipment, and military systems. Its small size and exceptional performance make it a versatile gain block which can improve power and gain in a single hermetically sealed package potentially replacing 2 or 3 narrower band amplifiers.

The UA0L65VM provides a complete amplifier module package with a wide frequency range of 100 kHz to 65 GHz, low power dissipation, ample output power, low noise figure and gain control.

## Key Specifications (Specifications pertain to case temperature range 0 to +75°C, and standard 2.4mm connectors)

$$V_{d1}=V_{d2}=V_{d3}=7V \text{ +/- } 5\%, V_{g1}=V_{g2}=-0.15V, V_{g3}=-0.05V; \quad Z_o=50\Omega$$

### FREQUENCY DOMAIN

Parameter	Description	100 kHz – 30 GHz			30-50 GHz		
		Min	Typ	Max	Min	Typ	Max
S21 (dB)	Small Signal Gain	27	30		24	30	
S11 (dB)	Input Match		-15	-10		-12	-8
S22 (dB)	Output Match		-15	-10		-8	-6

\*  $V_{g1}/V_{g2}/V_{g3}$  adjusted for peak gm

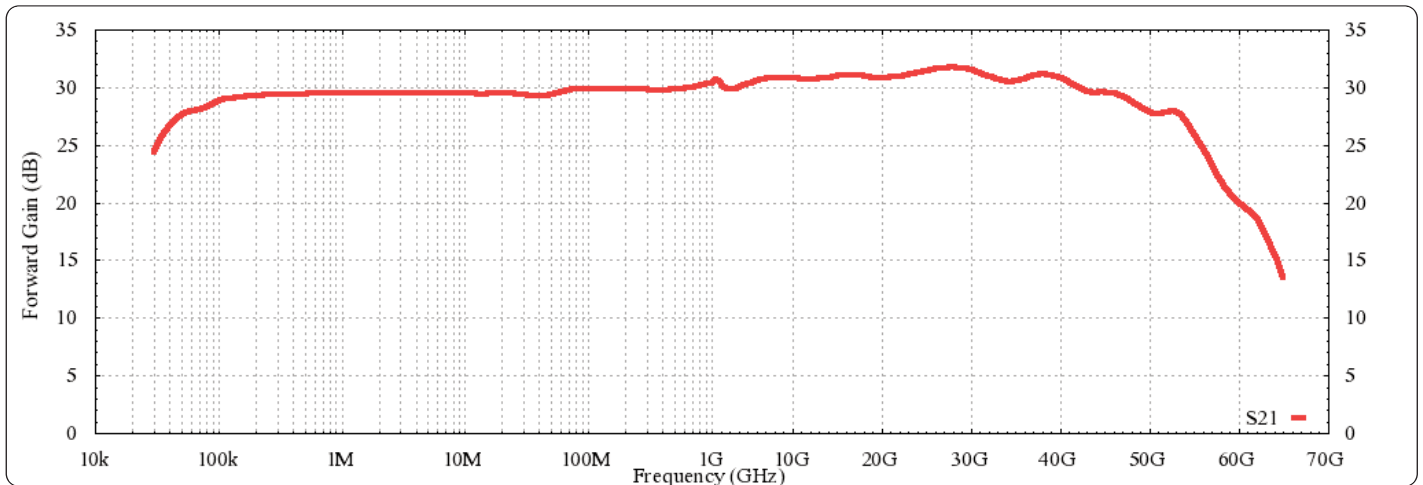

Small Signal, forward gain (S21) vs. Frequency

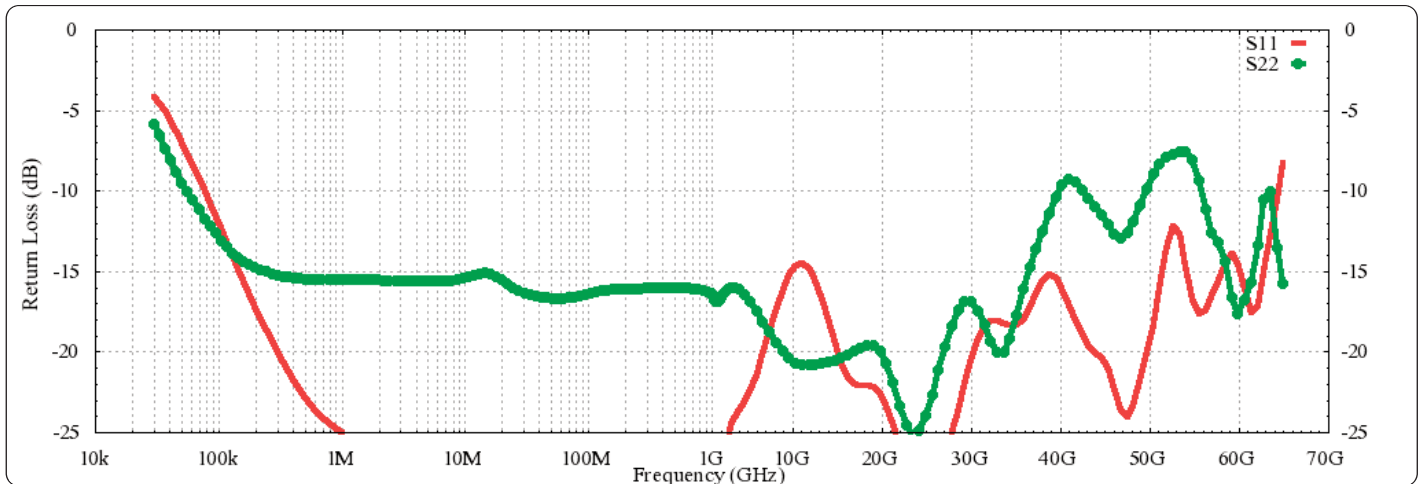

Small signal, input (S11) & output return (S22) loss vs. Frequency

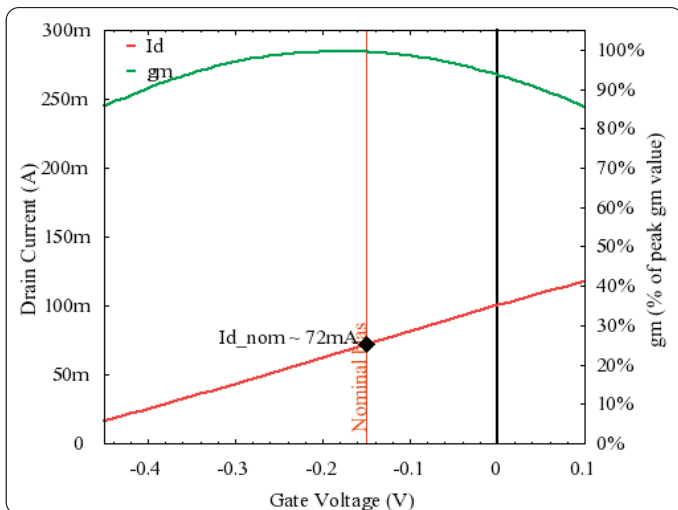

Drain Current and gm vs. Gate Voltage 1st and 2nd amplifier stages

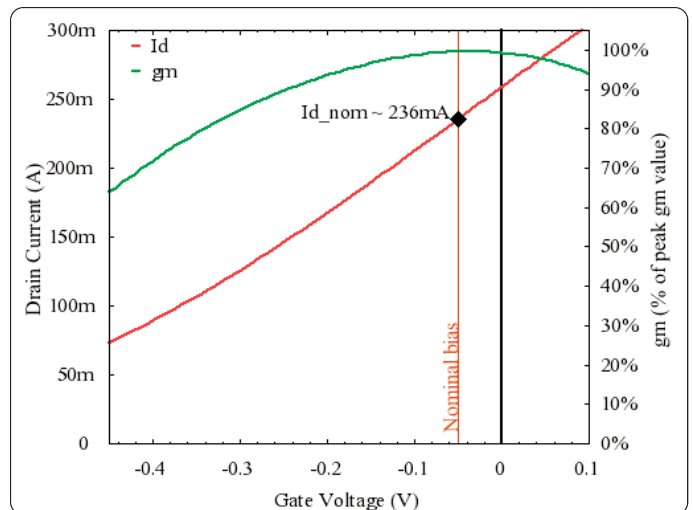

Drain Current and gm vs. Gate Voltage 3rd amplifier stage

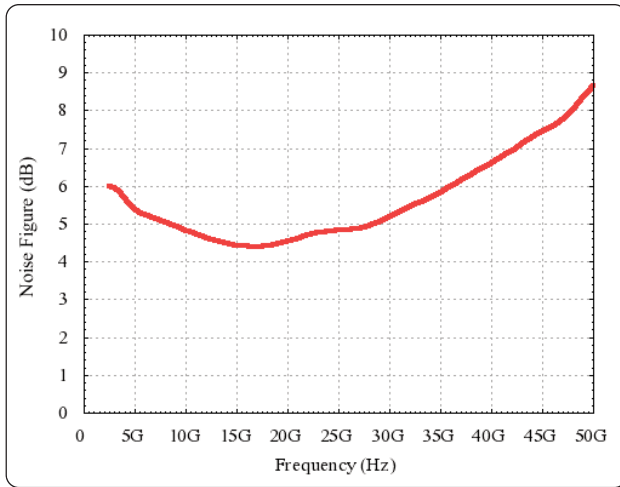

Noise Figure vs. Frequency

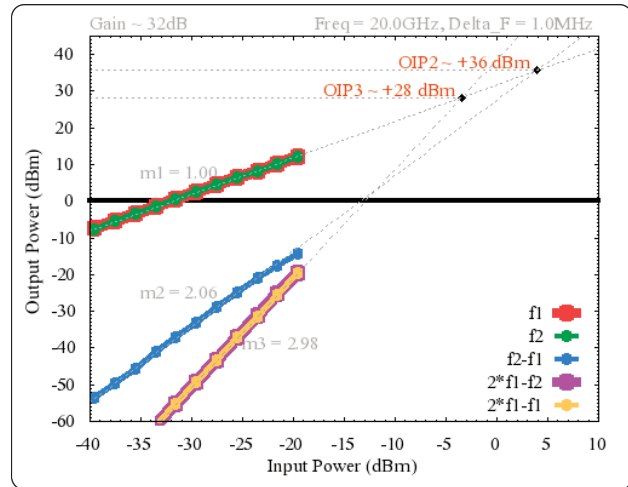

Two Tone Performance @ 20 GHz

Delta frequency = 1MHz

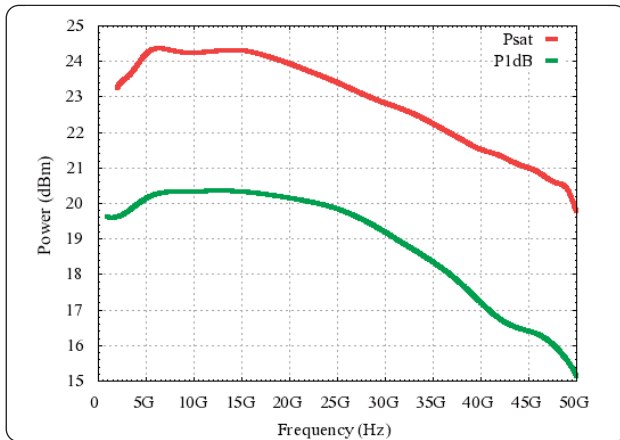

P1db and Psat vs. Frequency

## UA0L65VM Options

- OPT240: with Female Input 2.92mm (K) Connector
- OPT241: with Male Input 2.92mm (K) Connector
- OPT242: with Female Output 2.92mm (K) Connector
- OPT243: with Male Output 2.92mm (K) Connector
- OPT250: with Female Input Precision 2.4mm Connector (Standard)
- OPT251: with Male Input Precision 2.4mm Connector
- OPT252: with Female Output Precision 2.4mm Connector
- OPT253: with Male Output Precision 2.4mm Connector (Standard)
- OPT260: with Female Input 1.85mm (V) Connector
- OPT261: with Male Input 1.85mm (V) Connector
- OPT262: with Female Output 1.85mm (V) Connector
- OPT263: with Male Output 1.85mm (V) Connector
- OPT271: with Male Input GPPO Connector
- OPT273: with Male Output GPPO Connector
- OPTBLU: with Bent Leads (Up)
- OPTBLD: with Bent Leads (Down)

## Absolute Maximum Ratings\*

Parameter	Description	Minimum	Maximum
Vd1 (V)	First Drain Voltage		9
Vd2 (V)	Second Drain Voltage		9
Vd3 (V)	Third Drain Voltage		9
Id1 (mA)	First Drain Current		250
Id2 (mA)	Second Drain Current		250
Id3 (mA)	Third Drain Current		400
Vg1 (V)	First Gate Voltage	-1.5	1
Vg2 (V)	Second Gate Voltage	-1.5	1
Vg3 (V)	Third Gate Voltage	-1.5	1
Storage Temperature (C)		-55	125
Operating Case Temperature (C)		-25	85
Lead Soldering** (C)			260° for 3 sec.
RF Input Power (dBm)			20

## Recommended Operating Bias

Parameter	Typical
Vd1 (V)	7
Vd2 (V)	7
Vd3 (V)	7
Vg1 (V)	-0.15
Vg2 (V)	-0.15
Vg3 (V)	-0.05
Parameter	Typical
Vd1=7V, Vg1= -0.15V	Id1=72mA
Vd2=7V, Vg2= -0.15V	Id2=72mA
Vd3=7V, Vg3= -0.05	Id3=236mA
Power Dissipation	2.7W

\*Operation beyond the values listed under the Absolute Maximum Ratings may cause permanent damage to the device. These are stress ratings only, and functional operation of the device at these or any other conditions beyond those indicated in the recommended Operating Bias is not implied. Prolonged use at the absolute maximum rating conditions may affect device reliability.

\*\*The use of a heat sink between the component body and the solder joint is highly recommended.

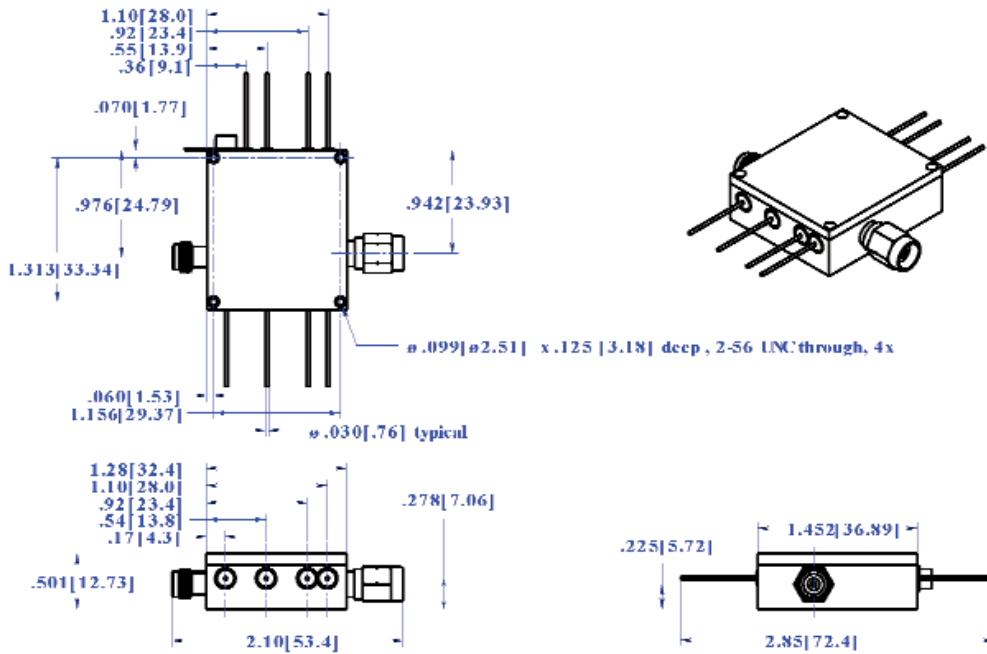

Typically, machined parts are within  $\pm 0.0025"$ . Pin lengths are  $\pm 0.010"$ .

## Physical Characteristics

(all measurements in inches[mm])

Tolerance typically  $\pm 0.0025$ in  
( $\pm 0.0635$ mm)

DC pin diameter is 0.03in  
[0.76mm]

## UA0L65VM Pin Definition

Pin	Function	Operational Notes
RFin	RF Input	2.4mm Connector (f) standard, other options available
RFout	RF Output	2.4mm Connector (m) standard, other options available
1 (Vg1)	1st stage gate bias	Adjust for optimum gain
2 (Vg2)	2nd stage gate bias	Adjust for optimum gain
3 (Vg3)	3rd stage gate bias	Adjust for optimum gain
4	NC	Not Connected
5 (Vd1)	1st stage drain bias	Set at typical operating specification
6 (Vd2)	2nd stage drain bias	Set at typical operating specification
7 (Vd3)	3rd stage drain bias	Set at typical operating specification
8	NC	Not Connected

Bias Recommendations (in order):

- 1) Set gate bias to recommended values; 2) Apply Bias Drains; 3) Adjust bias for optimum gain (maximum gm)

**Versatile Bias Board (TE1B) Available.**  
Please visit our website for more information