

SCHWARZBECK MESS - ELEKTRONIK

An der Klinge 29 D-69250 Schönau Tel.: 06228/1001 Fax.: (49)6228/1003

USLP 9143

UHF-SHF Log. - Per. Breitband Antenne
UHF-SHF Log. - Per. Broadband Antenna
0.3 - 5 GHz (0.25 - 7 GHz), 100 W

<i>Frequency</i>	<i>Distance</i>	<i>Wavelength</i>	<i>Attenuation</i>	<i>Gain (Isotr.)</i>	<i>Gain (Dipole)</i>	<i>Ant.-Factor</i>
Frequenz	Abstand	Wellenlänge	Dämpfung	Isotropgewinn	Gewinn über Dipol	Ant.-Wandlungsmaß
MHz	m	m	dB	dBi	dBd	dB/m
250.00	3.42	1.20	29.77	0.66	-1.50	17.52
275.00	3.42	1.09	26.45	2.73	0.58	16.28
300.00	3.35	1.00	21.68	5.40	3.25	14.36
325.00	3.29	0.92	21.35	5.83	3.68	14.63
350.00	3.23	0.86	21.48	6.02	3.87	15.08
375.00	3.19	0.80	22.19	5.90	3.75	15.80
400.00	3.15	0.75	24.58	4.93	2.78	17.33
425.00	3.11	0.71	25.46	4.71	2.56	18.08
450.00	3.08	0.67	24.82	5.23	3.08	18.05
475.00	3.05	0.63	24.30	5.69	3.54	18.07
500.00	3.03	0.60	23.94	6.05	3.90	18.15
550.00	2.99	0.55	24.71	6.02	3.87	19.01
600.00	2.95	0.50	24.84	6.28	4.13	19.50
650.00	2.92	0.46	25.42	6.29	4.14	20.19
700.00	2.89	0.43	25.79	6.39	4.24	20.73
750.00	2.87	0.40	26.03	6.53	4.38	21.19
800.00	2.85	0.38	27.34	6.13	3.98	22.15
850.00	2.83	0.35	27.57	6.25	4.10	22.56
900.00	2.82	0.33	26.46	7.03	4.88	22.28
950.00	2.80	0.32	26.70	7.12	4.97	22.65
1000.00	2.79	0.30	27.83	6.76	4.61	23.46
1100.00	2.77	0.27	28.95	6.58	4.43	24.47
1200.00	2.75	0.25	30.20	6.31	4.15	25.50
1300.00	2.73	0.23	30.00	6.73	4.58	25.77
1400.00	2.72	0.21	31.05	6.50	4.35	26.64
1500.00	2.71	0.20	31.98	6.32	4.17	27.42
1600.00	2.70	0.19	31.58	6.79	4.63	27.52
1700.00	2.69	0.18	33.73	5.96	3.81	28.87
1800.00	2.68	0.17	34.07	6.02	3.87	29.30
1900.00	2.68	0.16	33.21	6.68	4.53	29.12
2000.00	2.67	0.15	35.64	5.68	3.52	30.56
2100.00	2.66	0.14	37.11	5.14	2.99	31.52
2200.00	2.66	0.14	36.00	5.89	3.74	31.18
2300.00	2.65	0.13	36.20	5.98	3.83	31.48
2400.00	2.65	0.13	38.69	4.91	2.76	32.91
2500.00	2.65	0.12	39.14	4.86	2.70	33.32
2600.00	2.64	0.12	38.40	5.39	3.24	33.13
2700.00	2.64	0.11	38.46	5.52	3.37	33.33
2800.00	2.64	0.11	38.49	5.66	3.51	33.51
2900.00	2.63	0.10	39.60	5.25	3.10	34.22
3000.00	2.63	0.10	40.06	5.16	3.01	34.60

SCHWARZBECK MESS - ELEKTRONIK

An der Klinge 29 D-69250 Schönau Tel.: 06228/1001 Fax.: (49)6228/1003

USLP 9143

UHF-SHF Log. - Per. Breitband Antenne

UHF-SHF Log. - Per. Broadband Antenna

0.3 - 5 GHz (0.25 - 7 GHz), 100 W

Frequency	Distance	Wavelength	Attenuation	Gain (Isotr.)	Gain (Dipole)	Ant.-Factor
Frequenz	Abstand	Wellenlänge	Dämpfung	Isotropgewinn	Gewinn über Dipol	Ant.-Wandlungsmaß
MHz	m	m	dB	dBi	dBd	dB/m
2500.00	2.65	0.12	39.14	4.86	2.70	33.32
2600.00	2.64	0.12	38.40	5.39	3.24	33.13
2700.00	2.64	0.11	38.46	5.52	3.37	33.33
2800.00	2.64	0.11	38.49	5.66	3.51	33.51
2900.00	2.63	0.10	39.60	5.25	3.10	34.22
3000.00	2.63	0.10	40.06	5.16	3.01	34.60
3100.00	2.63	0.10	40.55	5.05	2.90	34.99
3200.00	2.62	0.09	40.33	5.30	3.15	35.02
3400.00	2.62	0.09	41.53	4.95	2.80	35.90
3600.00	2.62	0.08	42.97	4.48	2.33	36.87
3800.00	2.61	0.08	42.86	4.76	2.61	37.06
4000.00	2.61	0.08	43.84	4.49	2.34	37.77
4200.00	2.61	0.07	45.58	3.82	1.67	38.86
4400.00	2.60	0.07	44.08	4.77	2.62	38.32
4600.00	2.60	0.07	43.33	5.34	3.19	38.14
4800.00	2.60	0.06	45.21	4.58	2.43	39.27
5000.00	2.60	0.06	47.11	3.80	1.65	40.40
5200.00	2.60	0.06	48.32	3.36	1.21	41.18
5400.00	2.59	0.06	46.92	4.23	2.07	40.64
5600.00	2.59	0.05	45.48	5.10	2.95	40.08
5800.00	2.59	0.05	47.15	4.42	2.26	41.07
6000.00	2.59	0.05	47.43	4.42	2.27	41.36
6200.00	2.59	0.05	47.58	4.49	2.33	41.58
6400.00	2.59	0.05	47.09	4.87	2.72	41.48
6600.00	2.59	0.05	47.04	5.02	2.87	41.59
6800.00	2.59	0.04	48.15	4.60	2.45	42.27

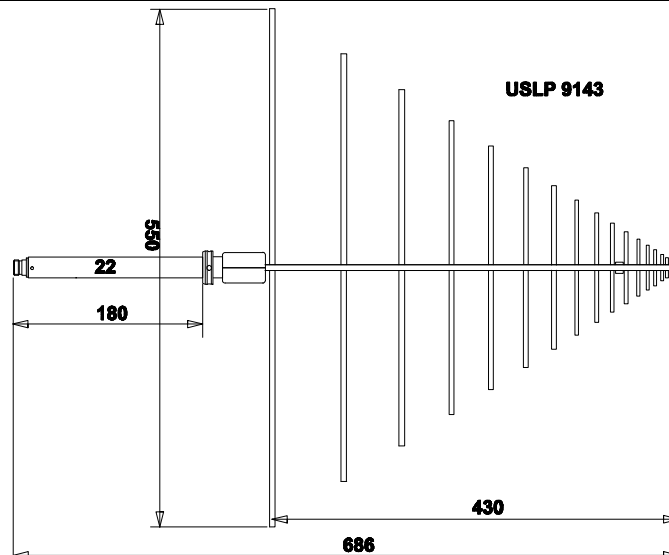

SCHWARZBECK MESS - ELEKTRONIK

An der Klinge 29 D-69250 Schönau Tel.: 06228/1001 Fax.: (49)6228/1003

USLP 9143

UHF-SHF Log. - Per. Breitband Antenne
UHF-SHF Log. - Per. Broadband Antenna
0.3 - 5 GHz (0.25 - 7 GHz), 100 W

USLP 9143 Isotropgewinn

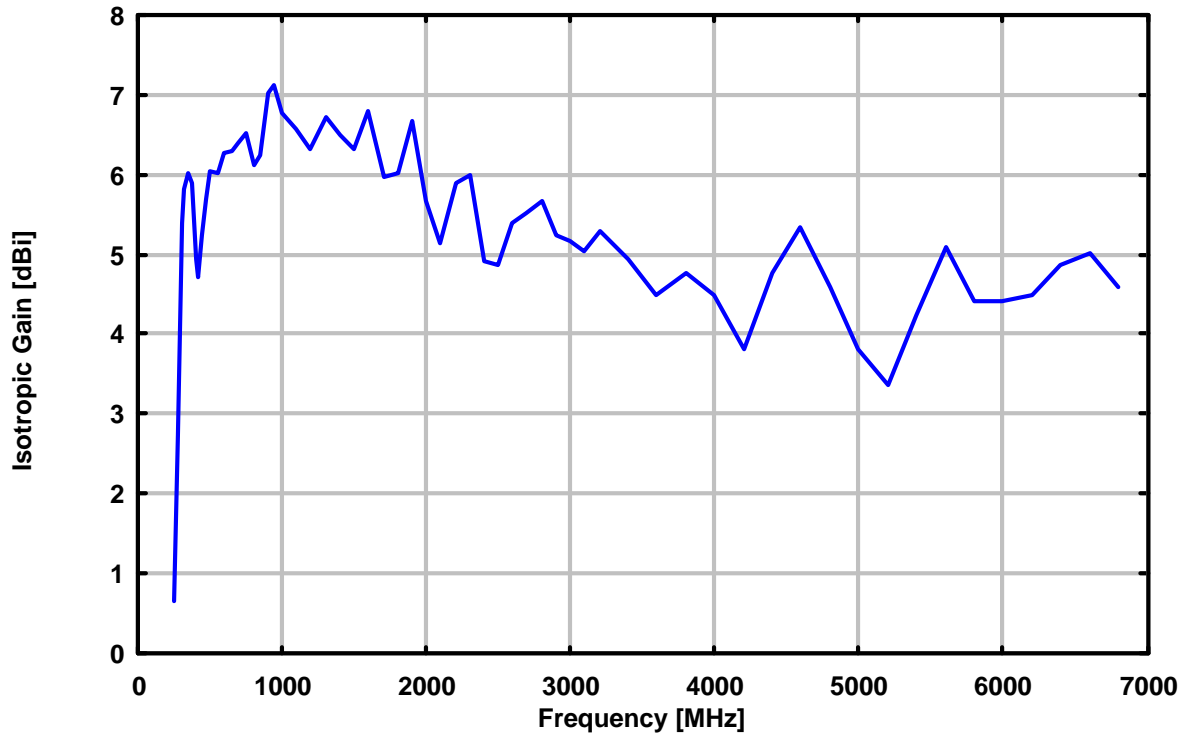

USLP 9143 Antennen-Wandlungsmass

