

The Truth About Arc Detection

by Adam Braverman, Associated Research

There seems to be no limit to the questions regarding the benefits and pitfalls of arc detection.

With the ever-increasing list of features and options available for equipment in the field of test and measurement, it is getting more challenging to select the appropriate instrument for the job. One feature that has caused substantial confusion is arc detection, which often is added to the dielectric withstand test commonly referred to as the hipot test. Ever since this feature's inception, there has been wide speculation surrounding arc detection, mostly due to the varying definitions and inconsistent claims made by hipot manufacturers.

Although hipot testers have been equipped with arc detection circuitry since 1996, many customers still are confused about it. When should arc detection be used? What are the benefits of arc detection? Are there any potential problems associated with arc detection?

What Is Arc Detection?

To understand arc detection, it is necessary to determine what is arcing. Arcing is defined as a momentary partial discharge due to the intense

concentration of a high-voltage electric field across a dielectric. In the case of hipot testing, this dielectric usually is the DUT's insulation.

Many times an arcing condition can be seen as a luminous discharge caused by the ionization of air molecules called corona. High-impedance arcing is a temporary condition, and it is not necessarily considered a sign of dielectric breakdown—the condition that a hipot tester originally was designed to test.

Dielectric breakdown causes a massive amount of leakage current to flow through a product's insulation while arcing usually produces momentary spikes in the nominal leakage current waveform. Arc detection circuitry was implemented to differentiate between these two conditions (**Table 1**).

An investigation of a specific safety agency standard provides us with a practical explanation of the difference between dielectric breakdown and arcing:

IEC 60601-1 Medical Electronic Equipment Section 20.4f states the following: "During the test, no flashover or breakdown shall occur. Slight corona discharges are neglected, provided that they cease when the test voltage is temporarily dropped to a lower value, which must be higher, however, than the *reference voltage (U)* and provided that the discharges do not provoke a drop in the test voltage."

Arcing	Breakdown
Temporary condition due to imperfections in the insulation that may be seen as flashover or corona	Catastrophic insulation failure condition that becomes evident at lower voltages during each subsequent test
Causes brief spikes in leakage current measurements	Causes excessive and dangerous amount of leakage current flow
May occur in products that are still electrically safe, depending on testing standard	Always the sign of a faulty product that isn't fit for production or sale

Table 1. A Comparison of Arcing and Breakdown Conditions

Continued on page 58

According to the standard, arcing and corona aren't necessarily indicative of a dielectric breakdown. In some cases, however, arcing can be a sign of a problem with the DUT's insulation or the manufacturing process.

So how is an arc detected? High-impedance arcs and corona generate high-frequency current pulses that ride on the lower-frequency wave of the applied test-current waveform. These pulses may have a frequency ranging from less than 30 kHz to more than 1 MHz and be very short in duration. Many times these pulses last much less than 10 μ s (Figure 1).

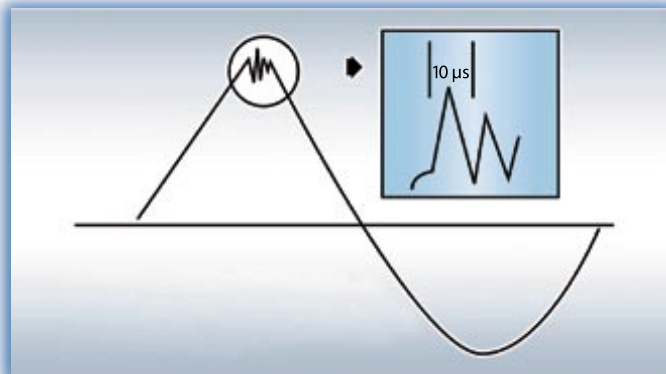

Figure 1. Arcing Condition

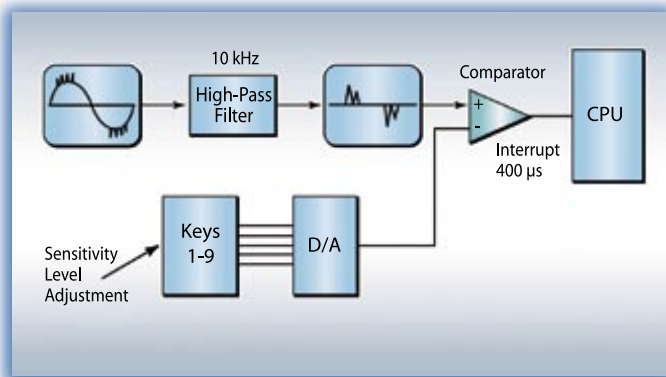

Figure 2. An Arc Detector

Associated Research's (AR) arc detection circuitry consists of a high pass filter circuit that responds only to frequencies greater than 10 kHz. These high-frequency signals are fed into a comparator and checked against an operator-programmed sensitivity level selected during the test setup (Figure 2).

If this level is exceeded, an interrupt signal is fed into the CPU, which shuts down the hipot. The arc detec-

tion failure displayed by an AR hipot is separate from the high-limit failure displayed when dielectric breakdown has occurred.

Why Is Arc Detection Important?

An arc causes momentary high-frequency current spikes that ride on the low-frequency current waveform. Although these current spikes may not be the result of a catastrophic breakdown of the DUT's insulation, they could indicate a problem with the insulation system that might become a safety issue at a later date.

For instance, sometimes arcing can occur as the result of a series fault condition. Usually stemming from a manufacturing defect such as a loose connection, a series fault condition creates an arc that is current-limited by the impedance of the circuit it is in series with. Since the arc is current-limited, this condition never will trigger the high-limit failure monitored by a standard hipot test but could create a potential fire hazard. Without arc detection, manu-

facturers of products with inherent arcing conditions could potentially pass faulty products or products that may fail prematurely.

AR's arc detection circuitry allows for the hipot to differentiate between the current spikes caused by an arc's rate of change of current over time ($\Delta di/dt$) and the excessive leakage current associated with dielectric breakdown. Further, the arc detection

circuit permits the test operator to set a distinct sensitivity level corresponding to the arc intensity. If relatively low-level arcing is deemed permissible by the DUT's manufacturer, the arc detector can be set to a low sensitivity level so arcs of lower magnitude could be neglected while high-level arcs will result in an arc failure condition.

The addition of an adjustable sensitivity level, however, has led to discrepancies between arc detectors of different hipot manufacturers. Many hipot customers have questioned how the results can differ from manufacturer to manufacturer or even hipot to hipot. Despite these discrepancies, the addition of the arc detector to the hipot test does result in a hipot tester that provides manufacturers with more information about what is happening in their DUTs.

When Should Arc Detection Be Used?

From a quality-control standpoint, more information always is useful in determining product safety. Perhaps several products have been damaged during shipping, resulting in poor gap spacing between a conductor and the insulation. This condition may not result in a dielectric breakdown, but with arc detection turned on, it would be possible to catch this problem before the faulty products find their way into customers' hands.

Maybe the integrity of a product's insulation has been weakened during the manufacturing process or a component has become damaged during shipping and, when subjected to a hipot test, low-level arcing results. Although the product might pass the hipot test, the arc detector could pick up the arcing condition and produce an arc failure.

Despite the many scenarios in which arc detection can be beneficial, a major source of confusion surrounding the technology is the apparent lack of test standards for using arc detection during a hipot test. There are very few sources of information available to help a manufacturer determine if arc detection is a necessary part of a DUT's test procedure, and those standards that do exist are relatively subjective.

Even more puzzling, no specific arcing standard defines whether or not arcing is acceptable in electrical products and, if so, to what degree. Yet cues can be taken from other industries that deal with arcing and arc detection.

The number of specific industries that recently have mandated arc detection as part of quality control and product safety precautions is growing. For example, arc detection and arc fault circuit breakers now are standard in the airline industry for checking the integrity of wire harnesses on airplanes. And as of 2002, the National Electrical Code requires arc fault circuit interrupters installed in feeder and branch circuits of residences. These interrupters help to prevent arcing within homes and need to be tested using some sort of arc detection technology to ensure that they are in good working order.

There is one major benefit resulting from the vague standards associated with arc detection: Hipot testers that incorporate the arc detection feature have been refined with regard to operator control. The operator-programmable sensitivity level and the capability to enable or disable the arc detection feature help to increase the scope of the technology's benefits.

Ultimately, it is up to the manufacturer to determine whether or not to use the arc detector and, if so, at what sensitivity level. The flexibility of the technology does provide manufacturers with a choice, and the result is an extra measure of control when performing a hipot test.

Quantifying an Arc

Simply put, it is very difficult to accurately measure the current produced by an arc. This is due to the extreme number of variables inherent to an arcing condition.

The geometry of an arc is never a constant. For example, breakdown voltages may vary greatly between two rounded surfaces or two sharp points that have the same gap spacing.

The impedance and distributed capacitance of the circuits between the point where the arc is generated and the detector also may affect the $\Delta di/dt$ of the

current waveform being monitored. The amount of voltage, rate of rise, polarity, and the waveform all affect the speed with which corona and arcing conditions occur. Temperature, humidity, and atmospheric pressure all influence the voltage at which corona begins as well as breakdown voltage levels.

With so many variables, arc detection becomes more of an approximation than a science.

Results and Discrepancies

With so many variables involved in the equation, arc detection becomes more of an approximation than a science. Many manufacturers want to know if an arc detection circuit can be set up to measure current at a specific level. While it is possible to set up the circuit with distinct trip levels, the detection results obtained by the hipot tester may seem very inconsistent.

Failure to produce a known repeatable arcing condition means hipot manufacturers cannot accurately calibrate the arc detection sensitivity scales. In fact, the leakage current inherent in a hipot due to its circuit board traces, input and output transformers, and other components further complicates a hipot manufacturer's capability to create a universal quantifiable sensitivity scale.

An arc that causes a failure on one hipot model might not induce a failure on another model. The sensitivity scale needs to change as a result of the output impedance of a specific hipot. As a result, an arc detector sensitivity measurement must be used to approximate arc level intensity, not quantify it. Unfortunately, this approximation of detecting arc intensity is where the majority of hipot manufacturers differ.

AR's arc-detection sensitivity settings are based on a scale of levels 1 through 9, with 1 being the least sensitive and 9 being the most sensitive. These sensitivity levels only loosely correspond to current levels of 20-2 mA.

Summary

Today's hipot testers come equipped with a variety of features designed to verify the safety and integrity of electrical products. While the primary purpose of the hipot test is to ensure a product's insulation system is sufficient enough to prevent against electric shock, most hipot testers have arc detection circuitry as well. The addition of arc detection circuitry allows manufacturers to test their products for both dielectric breakdown and arcing conditions during a hipot test.

Dielectric breakdown is considered a catastrophic failure of the DUT's insulation system while arcing may or may not be considered a failure condition. In general, arc detection is only an approximate means of monitoring the arcing levels of a DUT due to the inherent variables of an arcing condition.

An arc detection failure should be treated as a tool to provide more information about the integrity of an electrical product's insulation and not be considered a valid substitute for a dielectric breakdown failure. In some cases, arc detection isn't necessary for a hipot test, but the option is available to any manufacturer that needs to test for arcing in the insulation of a DUT.

Whether testing products that are prone to defects as a result of the manufacturing process or providing a fail-safe test for product liability, arc detection can indeed be a useful tool. However, since there are no major safety agencies that specify arc detection to receive a listing, it becomes the manufacturer's responsibility to determine the value of arc detection for each application.

About the Author

Adam Braverman is a technical sales engineer at Associated Research. He has more than three years of experience in the power supply industry and has written several application articles on subjects involving electrical safety testing. Mr. Braverman received a B.S. in electrical engineering from Bucknell University. Associated Research, 13860 W. Laurel Dr., Lake Forest, IL 60045, 847-367-4077, e-mail: Adamb@asresearch.com

EE