

LINECHEK® II LINE LEAKAGE TESTER

QUICKSTART GUIDE

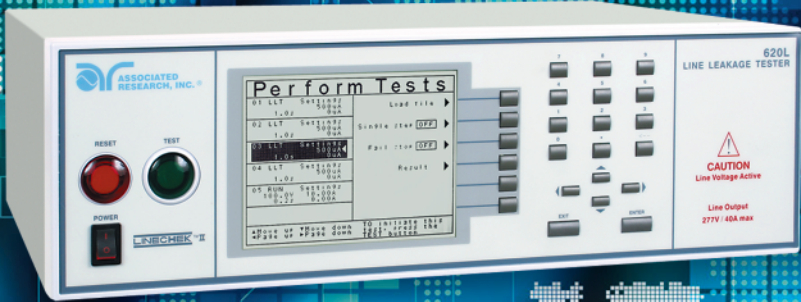

For the following model:
620L (Fully-Automated Line Leakage Tester)

SAFETY CHECKLIST

- KEEP** unqualified/unauthorized personnel away from test area
- ARRANGE** test stations in a safe and orderly manner
- NEVER** touch products or connections during a test
- STOP** the test first in the event of a problem
- NEVER** perform a ground bond test on energized circuitry or equipment
- BE SURE** to always connect the return test lead first
- HANDLE** test clips by insulation only, never touch clips directly



WARNING: THIS GUIDE WAS CREATED FOR OPERATORS HAVING SOME FAMILIARITY WITH ELECTRICAL SAFETY TESTING. AN ELECTRICAL SAFETY TESTER PRODUCES VOLTAGES AND CURRENTS THAT CAN CAUSE HARMFUL OR FATAL ELECTRIC SHOCK. TO PREVENT ACCIDENTAL INJURY OR DEATH, THESE SAFETY PROCEDURES MUST BE STRICTLY OBSERVED WHEN HANDLING AND USING A TEST INSTRUMENT.



FRONT PANEL CONTROLS

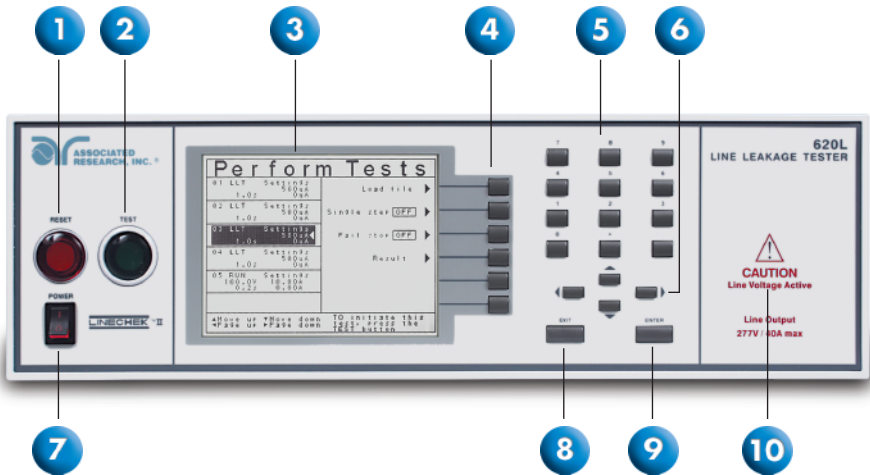

- 1. RESET BUTTON:** Resets the instrument. If a failure condition occurs during a test, pressing this button will reset the system, shut off the alarm and clear the failure condition. The Reset button must be pressed before performing another test or changing any of the setup parameters. This button also serves as an abort signal to stop any test in progress.
- 2. TEST BUTTON:** Starts a test.
- 3. GRAPHIC LCD:** 320 X 240 Monographic LCD.
- 4. SOFT KEYS:** Multifunction keys used to select screens and change parameters.
- 5. NUMERIC DATA ENTRY:** Keys used to enter numeric data.
- 6. UP, DOWN, LEFT, AND RIGHT, ARROW KEYS:** Keys used to scroll the highlighted area or cursor, up and down, left and right. When more than 5 steps are programmed in a test file, the left and right arrow keys will page through the screens of steps. The screens where the paging function is available are: Setup Tests, Perform Tests, Results Summary, and Results.
- 7. POWER SWITCH:** Turns the Hipot tester ON or OFF.
- 8. EXIT KEY:** Key used to escape from parameter editing and return to prior screens.
- 9. ENTER KEY:** Key used to finalize parameter entries. The ENTER key may also be used to scroll the highlighted area to different parameters in the parameter setting screens.
- 10. LINE VOLTAGE INDICATOR:** This indicator flashes to warn the operator that line voltage is present at the voltage output terminal.

BACKPANELCONTROLS

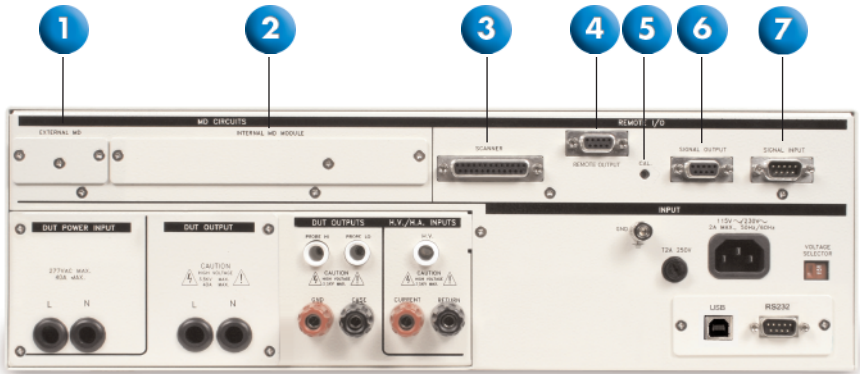

- 1. EXTERNAL MEASURING DEVICE:** Contains an external Measuring Device PCB that will enable during a Line Leakage test when “External” is selected from the “Meas. Device” soft key. The external MD allows the operator to configure a custom measuring device using either a simple resistive component or a complex two pole network.
- 2. INTERNAL MD MODULE:** Provides the operator access to the measuring device that is currently selected. The BNC connector may be used to monitor that voltage directly across the terminals of the MD.
- 3. SCANNER CONNECTOR:** For connection of optional external 8 channel Scanner.
- 4. REMOTE OUTPUT:** For connection of optional AC1000 power source. When used to deliver DUT power, the AC1000 may be configured to work in a master/slave mode with the 620L.
- 5. CALIBRATION BUTTON:** To put the instrument into the calibration mode push this button and turn on the power switch simultaneously.
- 6. REMOTE SIGNAL OUTPUT:** 9-Pin D-type subminiature female connector for monitoring PASS, FAIL, and PROCESSING output relay signals.
- 7. REMOTE SIGNAL INPUT:** 9-Pin D-type subminiature male connector for remote control of TEST, RESET, and REMOTE INTERLOCK DISABLE functions, as well as MEMORY SELECTION.

BACKPANELCONTROLS

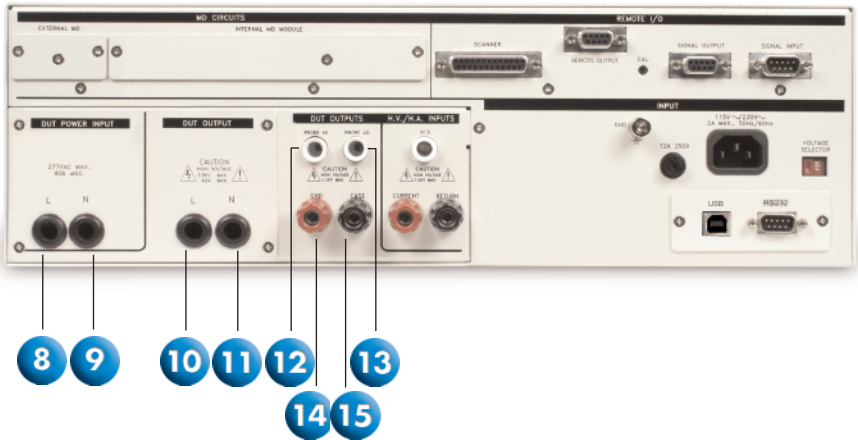

- 8. DUT POWER INPUT LINE:** Provides DUT input power (line connection). Only a single phase unbalanced power source may be used.
- 9. DUT POWER INPUT NEUTRAL:** Provides DUT input neutral power (neutral connection). Only a single phase unbalanced power source may be used.
- 10. DUT POWER OUTPUT:** Provides line power (line connection) to the DUT during Line Leakage and Functional Run testing.
- 11. DUT POWER OUTPUT:** Provides line power (neutral connection) to the DUT during Line Leakage and Functional Run testing.
- 12. PROBE HI:** Connector used to attach the Probe-HI test lead to the DUT. When used with an appropriate test lead, this terminal connects one side of the MD (measuring device) to the DUT during Enclosure or Applied Part Line Leakage tests. This terminal will be enabled during a Line Leakage test whenever Probe-HI has been selected.
- 13. PROBE LO:** Connector used to attach the Probe-LO test lead to the DUT. When used with an appropriate test lead, this terminal connects one side of the MD (measuring device) to the DUT during Applied Part Line Leakage tests. The terminal is always used in conjunction with the Probe-HI terminal.
- 14. GND:** Connector used to attach the adapter box Ground lead to the instrument.
- 15. CASE (Optional):** Connector used to attach the return lead to the DUT case or dead metal. Provides the return for the Ground Bond, Dielectric Withstand, and Insulation Resistance tests. During a Line Leakage test and Functional Run test, this terminal is isolated from the test circuits.

BACKPANELCONTROLS

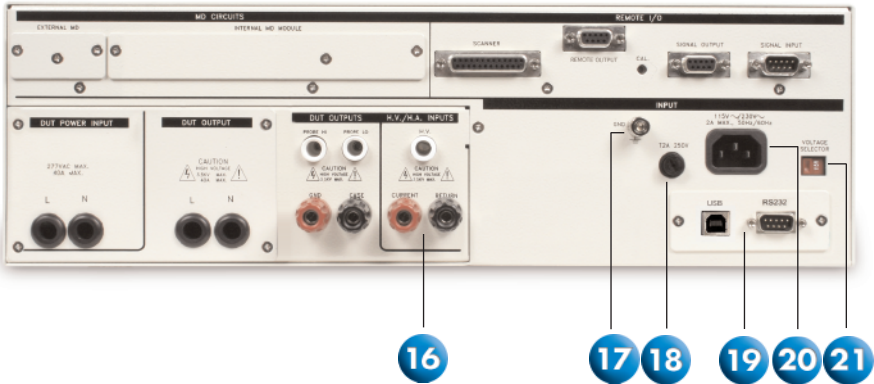

- 16. SAFETY TESTER CONNECTIONS (Optional):** Connector used to interface the 620L to an Associated Research electrical safety tester.
- 17. CHASSIS GROUND (Earth) CONNECTION:** This terminal should be connected to a good earth ground before operation
- 18. FUSE RECEPTACLE:** To change the fuse, unplug the power (mains) cord and turn the fuse receptacle counter-clockwise. The fuse compartment will be exposed. Please replace the fuse with one of the proper rating.
- 19. BUS INTERFACE:** Standard connector for interconnection to the USB/RS-232 Bus interface. Optional IEEE-488 interface may be substituted for the USB/RS-232.
- 20. INPUT POWER RECEPTACLE:** Standard IEC 320 connector for connection to a standard NEMA style line power (mains) cord.
- 21. INPUT POWER SWITCH:** Sets the line voltage configuration of the instrument. In the left position it is set for 115 volt operation, in the right position it is set for 230 volt operation.



WARNING: LOCATE A SUITABLE TESTING AREA WITH A THREE-PRONG, GROUNDED OUTLET. BE SURE THAT YOUR THREE-PRONG OUTLET HAS BEEN TESTED FOR PROPER WIRING. ALSO, MAKE SURE YOU READ THE SAFETY CHECKLIST OF THIS GUIDE BEFORE STARTING TO TEST.

1. Choose the correct input line voltage on the rear panel of the instrument, either 115V AC or 230V AC.
2. Connect the line cord into the rear of the instrument and plug the male end of the cord into a grounded power source.
3. Plug the interlock connector into the Signal Input connector on the rear panel of the instrument. LINECHEK is equipped with a Remote Interlock feature, which utilizes a set of closed contacts to enable the instrument's output. In order to perform a test, the interlock connector must be plugged into the Signal Input connection on the rear panel of the instrument.
4. Turn the POWER switch to ON.

The initialization screen will appear. After three seconds the Perform Test Screen will appear as shown below.

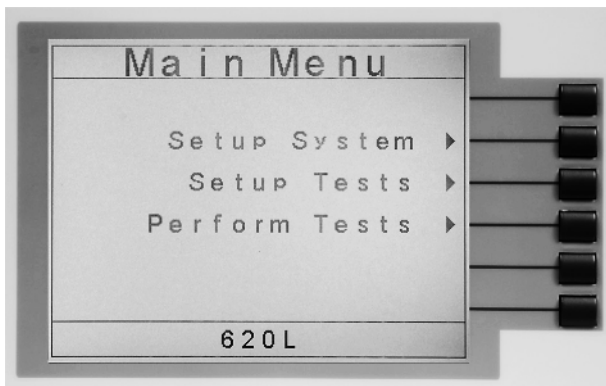

CHANGING TEST SETTINGS

ADDING A NEW TEST

From the Main Menu screen, press the "Setup Tests" soft key.

On the Setup Tests screen, the test and step number will be highlighted.

Press the "Add" soft key and specify the type of test with the soft key options given (Run Test (optional feature), Line Leakage test).

The parameters for the chosen test type will appear. Use the soft keys to edit parameters on the right side of the screen (examples: neutral, reverse, ground).

Use the up and down arrows to scroll between and edit test parameters on the left side of the screen (examples: leakage-hi, leakage-lo, voltage-hi).

Use the numeric keypad to change a parameter value. Once the user has entered the desired parameter, press the ENTER key to save.

Press EXIT to go back to the Setup Tests screen to add another test or press EXIT again to go back to the Main Menu.

EDITING & DELETING TESTS

If the default settings do not apply to user specifications, the test parameters are fully adjustable. Common parameters that can be adjusted include leakage-hi, leakage-lo, voltage-hi, voltage-lo, delay time, and dwell time.

From the Main Menu screen, press the "Setup Tests" soft key.

Use the arrow keys (up, down) to highlight the test to be edited and hit the "Edit" soft key.

Select a parameter to edit by scrolling with the up and down arrow soft keys.

Use the numeric keypad to adjust the parameter value.

Once the user has entered the desired value, press the ENTER key to save.

Press EXIT twice to get back to the Main Menu screen.

Deleting a test step is also done from the Setup Tests menu. Highlight the test to be deleted and hit the "Delete" soft key.

Press ENTER and the step will be deleted. Pressing EXIT will abort the deletion of the test.

CHANGING TEST SETTINGS

SAVING AND LOADING TEST FILES

Multiple tests for a particular product or individual product can be saved in files for an easy recall of test conditions.

From the Main Menu screen, press the "Setup Tests" soft key.

Hit the "File" soft key from the Setup Tests window. The files currently on the system will be displayed.

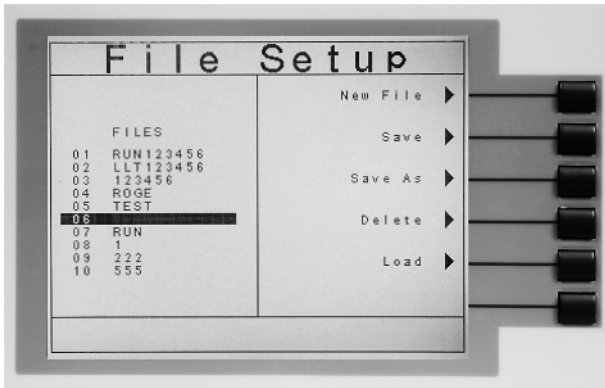

Using the up and down arrow keys, highlight the number of the file slot where the test sequence is to be saved. Hit the "Save As" soft key and the Create File screen will appear.

Use the arrow keys (up, down, left, right) to select letters on the virtual keypad or use the numeric keypad to enter numbers for the file name. When finished, hit the ENTER key. The system will exit back to the "Setup Tests" screen with the current file now loaded.

To recall any test file, hit the "File" soft key from the Setup Tests screen.

Use the up and down arrow keys to select the file to be loaded. Hit the "Load" soft key and the test sequence associated with the file will automatically be loaded.

CONNECTIONS

DUT INPUT POWER CONNECTIONS

Remove the cover plate on the rear panel of the 620L to access the DUT Power Input Connections. These terminals provide the connections from an external power source to the 620L.

Once removed, use the black 10 AWG cables (included) to connect to an unbalanced, single-phase power source for applications up to and including 40 amps.

The 220 - 240V US style line power IS NOT suitable to connect to the DUT inputs. This style of power distribution is a balanced type with two HOT or LINE conductors.



WARNING: BE SURE THAT THE HOT LEAD OF THE POWER SOURCE IS CONNECTED TO PIN 1, L (LINE) TERMINAL OF THE DUT POWER INPUT TERMINAL BLOCK AND THE RETURN OR LOW VOLTAGE LEAD IS CONNECTED TO PIN 2, N (NEUTRAL) TERMINAL OF THE DUT POWER INPUT TERMINAL BLOCK. DO NOT CONNECT A LINE CONDUCTOR TO THE N OR NEUTRAL TERMINAL OF THE DUT POWER INPUT. THIS CONDITION CAN BE VERY DANGEROUS TO THE OPERATOR.

If voltage is applied to pin 2, N (neutral) terminal of the DUT Power Input and you attempt to execute a Run Test or Line Leakage test, a warning message will appear in the displayed messages portion of the screen that says Neutral-V.

If you see this message, you will need to correct the voltage problem before the instrument will allow you to execute Run Tests or Line Leakage tests.

DUT OUTPUT POWER CONNECTIONS

Remove the cover plate on the rear panel of the 620L. These connections provide power to the DUT during a Line Leakage or Functional Run test.

Once removed, the set of black 10 AWG cables (included) may be used for the DUT Output connections for applications up to and including 40 amps.

CONNECTIONS

TEST LEAD CONNECTIONS

Connect one or more of the black, alligator clip-terminated cables to the Probe-HI and Probe-LO terminals on the rear panel of the 620L. These cables are used to measure leakage current during either a Line Leakage test or a Functional Run test.

Connect the red test lead (also terminated in an alligator clip) to the GND terminal on the rear panel of the 620L. This will provide the return connection for all leakage current measurements.

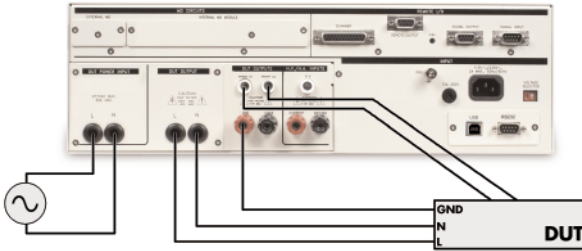

ADAPTOR BOX CONNECTIONS

The adaptor box may be used for products that are terminated in either a two prong or three prong line cord.

Connect the adaptor box to the DUT Output L (line) and N (neutral) terminals, and the GND terminal.

The adaptor box will now provide power to the DUT during Line Leakage testing and Functional Run testing.

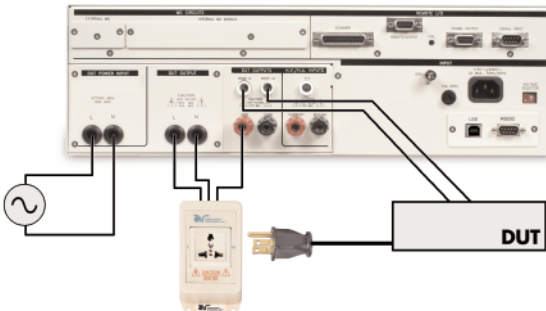

WARNING: THE ADAPTOR BOX MAY ONLY BE USED FOR APPLICATIONS UNDER 20 AMPS. IF AN APPLICATION IN WHICH MORE THAN 20 AMPS OF INPUT CURRENT IS REQUIRED, PLEASE USE THE STAND-ALONE INPUT AND OUTPUT CABLES PROVIDED WITH THE INSTRUMENT.

TESTRESULTS

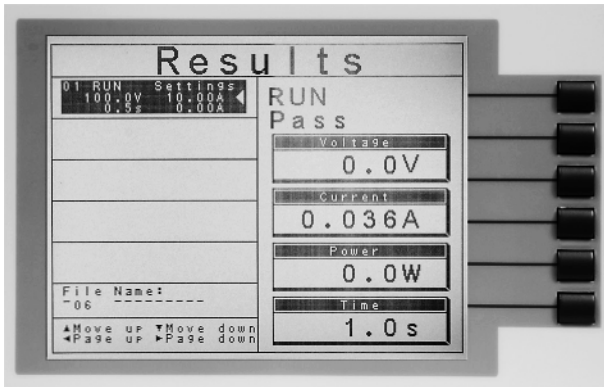

VIEWING TEST RESULTS

From the Perform Tests screen, press the “Results” soft key.

Use the up and down arrows to select the test to be reviewed or use the left and right arrows to scroll between memories.

Results are displayed on the right hand side of the screen including the test type, reason for failure and test parameter results.

Press the EXIT key to go back to the Perform Tests screen and hit EXIT again to go back to the Main Menu.

INTERCONNECTION

620L LINECHECK II INTERCONNECTION

In order to interconnect the LINECHECK II to the OMNIA 8104 Electrical Safety Compliance Analyzer, system settings must change on the OMNIA.

First activate the PLC remote on the OMNIA

Choose SETUP SYSTEM from the Main Menu screen

Select HARDWARE from the Setup System screen

Use the + and - soft keys to turn the PLC Remote Setting to ON.

Press EXIT twice to return to the Main Menu Screen.

INTERCONNECTION

INTERCONNECTION OF 620L LINECHECK II TO OMNIA 8104 AND CONNECTION TO A DEVICE UNDER TEST

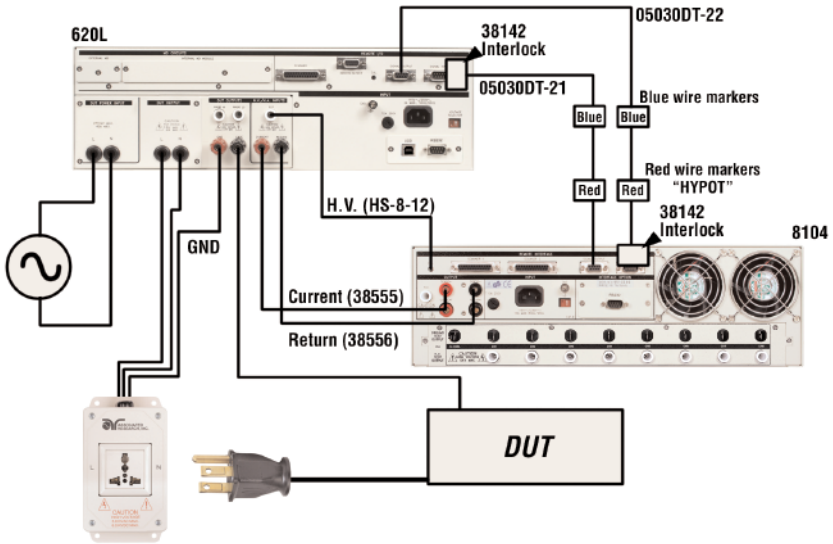

1. Plug the double sided interlocks (P/N 38142) into the signal inputs of both instruments.
2. Using the rear panel connections, connect the following cords:
3. P/N 38556 - Plug one end into the rear panel return and sense (-) jack on the OMNIA. Hook the other end on to the return jack on the rear panel of the 620L.
4. P/N 38555 - Plug one end into the rear panel current and sense (+) jack on the OMNIA. Hook the other end on to the current jack on the rear panel of the 620L.
5. P/N HS-8-12 - Plug one end into the rear panel HV port on the OMNIA. Plug the other end into the HV port on the rear panel of the 620L.
6. P/N 05030DT-21 - Plug the blue coded end into the 620L interlock connector. Plug the red coded end into the OMNIA signal output.
7. P/N 05030DT-22 - Plug the blue coded end into the 620L signal output. Plug the red coded end into the OMNIA interlock connector.
8. P/N CBLHC40-10TL - Hook the black Case lead to the rear panel Case connection on the 620L. Then connect the clip end of the test lead to the chassis ground of the DUT.
9. P/N 38777 - Remove the DUT INPUT/ DUT OUTPUT plate cover from the rear panel of the 620L. Using a screwdriver, screw in the line and neutral connections of the 620L adapter box to the L and N posts on the DUT OUTPUT on the rear panel of the 620L. Next, hook the GND lug on the adapter box to the GND jack on the rear panel of the 620L.
10. Connect line and neutral from an unbalanced power supply into the L and N posts on the DUT INPUT on the rear panel of the 620L.
11. Plug the DUT line cord into the adapter box.

For additional information about these and other key features of the LINECHECKII, please consult the full Operation and Service Manual or call us toll-free 1-800-858-TEST (8378) or +1-847-367-4077
©2011 Associated Research, Inc. www.asresearch.com